



SERVO DRIVE

FlexDrive^{II} / Flex+Drive^{II}

Servo Controls

Installation Manual

Contents

1	General Information	1-1
2	Introduction	2-1
2.1	FlexDrive ^{II} features	2-1
2.2	Receiving and inspection	2-2
2.2.1	Identifying the catalog number	2-2
2.3	Units and abbreviations	2-3
3	Basic Installation	3-1
3.1	Introduction	3-1
3.1.1	Power sources	3-1
3.1.2	Hardware requirements	3-1
3.1.3	RS485 / RS422 systems	3-2
3.1.4	Tools and miscellaneous hardware	3-2
3.1.5	Other information needed for installation	3-3
3.2	Mechanical installation and location requirements	3-4
3.2.1	Mounting the FlexDrive ^{II}	3-5
3.2.2	Dimensions	3-6
3.3	Connector locations	3-7
3.4	Power connections	3-8
3.4.1	Single-phase connection to package sizes A, B, C, D	3-9
3.4.2	Three-phase connection to package sizes E, G, H	3-10
3.4.3	Input power conditioning	3-11
3.4.4	Power disconnect and protection devices	3-11
3.4.5	Power supply filters	3-12
3.4.6	Wire sizes and protection device ratings	3-13
3.4.7	External customer supplied 24V control supply	3-14
3.5	Motor connections	3-15
3.5.1	Motor circuit contactors	3-16
3.5.2	Motor power cable pin configuration - Baldor BSM rotary motors	3-16
3.5.3	Motor cable pin configuration - Baldor linear motors	3-17
3.5.4	Thermal switch connection	3-18
3.5.5	Motor brake connection	3-19
3.6	Regeneration resistor (Dynamic Brake resistor)	3-20
3.6.1	Controlling regeneration	3-20
3.7	Feedback connections	3-21
3.7.1	Resolver option - X8	3-22
3.7.2	Encoder option - X8	3-24
3.7.3	EnDat (absolute encoder) option - X8	3-27

3.8	Drive enable - X3	3-29
3.8.1	Drive enable - X3	3-29
3.8.2	Drive enable - SW1 DIP switch	3-30
3.8.3	Drive enable command	3-30
3.9	DIP switches - SW1	3-31
3.9.1	Switches 1-4	3-31
3.9.2	Switch 5 - Hold	3-32
3.9.3	Switch 6 - RS485 terminator	3-32
3.9.4	Switch 7 - Offset tuning	3-32
3.9.5	Switch 8 - Enable	3-32
3.9.6	Switches 9 and 10 - RS232/RS485 select	3-33
3.9.7	Factory settings	3-33
3.9.8	Preventing a program running at startup	3-34
4	Input / Output	4-1
4.1	Introduction	4-1
4.2	Analog I/O	4-1
4.2.1	Analog input - X3 (command)	4-2
4.2.2	Relay output - X3	4-4
4.3	Digital I/O	4-5
4.3.1	Digital inputs - X3	4-6
4.3.2	CREF and digital inputs	4-7
4.3.3	Special functions on DIN4 and DIN5 - pulse and direction inputs	4-7
4.3.4	Special functions on DIN4 and DIN5 - fast inputs	4-8
4.3.5	Digital outputs - X3	4-9
4.4	Other I/O	4-10
4.4.1	Encoder output - X7	4-10
4.4.2	Master (auxiliary) encoder input - X9	4-12
4.4.3	Serial port - X6	4-14
4.4.4	Using RS232 cable	4-15
4.4.5	Multidrop using RS485 / RS422 cable	4-16
4.4.6	Connecting Baldor HMI Operator Panels	4-17
4.5	Connection summary - minimum system wiring	4-18
4.6	Option connectors	4-19
5	Operation	5-1
5.1	Introduction	5-1
5.1.1	Connecting the FlexDrive ^{II} to the PC	5-1
5.1.2	Installing the software	5-1
5.1.3	Starting the FlexDrive ^{II}	5-2
5.1.4	Preliminary checks	5-2
5.1.5	Power on checks	5-2
5.1.6	Offset tuning	5-3

5.2	WorkBench v5	5-4
5.2.1	Help file	5-4
5.2.2	Starting WorkBench v5	5-5
5.2.3	Commissioning Wizard	5-7
5.2.4	Using the Commissioning Wizard	5-7
5.2.5	Completing the Commissioning Wizard	5-7
5.3	Further configuration	5-8
5.3.1	Fine-tuning tool	5-8
5.3.2	Parameters tool	5-10
5.3.3	Digital I/O tool	5-11
5.3.4	Other tools and windows	5-11
6	Troubleshooting	6-1
6.1	Introduction	6-1
6.1.1	Problem diagnosis	6-1
6.1.2	SupportMe™ feature	6-1
6.1.3	Power-cycling the FlexDrive ^{II}	6-1
6.2	FlexDrive ^{II} indicators	6-2
6.2.1	Status display	6-2
6.2.2	DB On (Regeneration) LED	6-5
6.2.3	Communication	6-5
6.2.4	Power on	6-6
6.2.5	Tuning	6-6
6.2.6	Status display shows a digit or 'E.'	6-6
7	Specifications	7-1
7.1	Introduction	7-1
7.1.1	AC input power and motor output - single-phase models	7-2
7.1.2	AC input power and motor output - 230V three-phase models	7-3
7.1.3	AC input power and motor output - 230-460V three-phase models	7-4
7.1.4	Customer supplied 24VDC supply input	7-4
7.1.5	Regeneration	7-5
7.1.6	Analog input (X3)	7-6
7.1.7	Digital inputs (X3)	7-7
7.1.8	Digital outputs (X3)	7-7
7.1.9	Relay output (X3)	7-8
7.1.10	Serial RS232 interface (X6)	7-8
7.1.11	Serial RS485 interface (X6)	7-8
7.1.12	Encoder output (simulated) (X7)	7-8
7.1.13	Resolver feedback option (X8)	7-9
7.1.14	Encoder feedback option (X8)	7-9
7.1.15	EnDat (absolute encoder) feedback option (X8)	7-9
7.1.16	Master (auxiliary) encoder input (X9)	7-10
7.1.17	Pulse and direction input (X9)	7-10
7.1.18	Environmental	7-11

Appendices

A	Accessories	A-1
A.1	Introduction	A-1
A.1.1	Factory fitted options	A-1
A.1.2	Motor power cables	A-2
A.1.3	Motor power cable part numbers	A-2
A.1.4	Feedback cables	A-3
A.1.5	Feedback cable part numbers	A-4
A.1.6	EMC filters	A-5
A.1.7	Regeneration resistors	A-7
B	Control System	B-1
B.1	Introduction	B-1
B.1.1	Current (Torque) control	B-2
B.1.2	Velocity (Speed) control	B-3
B.1.3	Position control (Pulse and Direction)	B-4
B.1.4	Position control	B-5
B.2	Control system operation	B-6
B.2.1	Position controller	B-6
B.2.2	Speed controller	B-7
B.2.3	Torque controller and feedback	B-8
C	CE Guidelines	C-1
C.1	Outline	C-1
C.1.1	EMC Conformity and CE marking	C-1
C.1.2	Use of CE compliant components	C-2
C.1.3	EMC wiring technique	C-2
C.1.4	EMC installation suggestions	C-3
C.1.5	Wiring of shielded (screened) cables	C-4

LT0160A02 Copyright Baldor (c) 2002. All rights reserved.

This manual is copyrighted and all rights are reserved. This document or attached software may not, in whole or in part, be copied or reproduced in any form without the prior written consent of Baldor. Baldor makes no representations or warranties with respect to the contents hereof and specifically disclaims any implied warranties of fitness for any particular purpose. The information in this document is subject to change without notice. Baldor assumes no responsibility for any errors that may appear in this document.

Mint™ is a registered trademark of Baldor.

Windows 95, Windows 98, Windows ME, Windows NT, Windows XP and Windows 2000 are registered trademarks of the Microsoft Corporation. UL and cUL are registered trademarks of Underwriters Laboratories. EnDat is a registered trademark of Heidenhain Corporation.

Limited Warranty

For a period of two (2) years from the date of original purchase, Baldor will repair or replace without charge controls and accessories that our examination proves to be defective in material or workmanship. This warranty is valid if the unit has not been tampered with by unauthorized persons, misused, abused, or improperly installed and has been used in accordance with the instructions and/or ratings supplied. This warranty is in lieu of any other warranty or guarantee expressed or implied. Baldor shall not be held responsible for any expense (including installation and removal), inconvenience, or consequential damage, including injury to any person or property caused by items of our manufacture or sale. (Some countries and U.S. states do not allow exclusion or limitation of incidental or consequential damages, so the above exclusion may not apply.) In any event, Baldor's total liability, under all circumstances, shall not exceed the full purchase price of the control. Claims for purchase price refunds, repairs, or replacements must be referred to Baldor with all pertinent data as to the defect, the date purchased, the task performed by the control, and the problem encountered. No liability is assumed for expendable items such as fuses. Goods may be returned only with written notification including a Baldor Return Authorization Number and any return shipments must be prepaid.

Product notice

Only qualified personnel should attempt the start-up procedure or troubleshoot this equipment. This equipment may be connected to other machines that have rotating parts or parts that are controlled by this equipment. Improper use can cause serious or fatal injury. Only qualified personnel should attempt to start-up, program or troubleshoot this equipment.

Safety Notice

Intended use: These drives are intended for use in stationary ground based applications in industrial power installations according to the standards EN60204 and VDE0160. They are designed for machine applications that require variable speed controlled three-phase brushless AC motors. These drives are not intended for use in applications such as:

- Home appliances
- Medical instrumentation
- Mobile vehicles
- Ships
- Airplanes.

Unless otherwise specified, this drive is intended for installation in a suitable enclosure. The enclosure must protect the drive from exposure to excessive or corrosive moisture, dust and dirt or abnormal ambient temperatures. The exact operating specifications are found in section 7 of this manual. The installation, connection and control of drives is a skilled operation, disassembly or repair must not be attempted. In the event that a drive fails to operate correctly, contact the place of purchase for return instructions.

Precautions



WARNING: Do not touch any circuit board, power device or electrical connection before you first ensure that no high voltage is present at this equipment or other equipment to which it is connected. Electrical shock can cause serious or fatal injury. Only qualified personnel should attempt to start-up, program or troubleshoot this equipment.



WARNING: Be sure the system is properly earthed/grounded before applying power. Do not apply AC power before you ensure that earths/grounds are connected. Electrical shock can cause serious or fatal injury.



WARNING: Be sure that you are completely familiar with the safe operation and programming of this equipment. This equipment may be connected to other machines that have rotating parts or parts that are controlled by this equipment. Improper use can cause serious or fatal injury. Only qualified personnel should attempt to program, start-up or troubleshoot this equipment.



WARNING: Be sure all wiring complies with the National Electrical Code and all regional and local codes. Improper wiring may result in unsafe conditions.



WARNING: The stop input to this equipment should not be used as the single means of achieving a safety critical stop. Drive disable, motor disconnect, motor brake and other means should be used as appropriate. Only qualified personnel should attempt to program, start-up or troubleshoot this equipment.



WARNING: Improper operation or programming of the drive may cause violent motion of the motor and driven equipment. Be certain that unexpected motor movement will not cause injury to personnel or damage to equipment. Peak torque of several times the rated motor torque can occur during control failure.



WARNING: The motor circuit might have high voltages present whenever AC power is applied, even when the motor is not moving. Electrical shock can cause serious or fatal injury.



WARNING: If a motor is driven mechanically, it might generate hazardous voltages that are conducted to its power terminals. The enclosure must be earthed/grounded to prevent possible shock hazard.



WARNING: When operating a rotary motor with no load coupled to its shaft, remove the shaft key to prevent it flying out when the shaft rotates.



WARNING: A regeneration resistor may generate enough heat to ignite combustible materials. To avoid fire hazard, keep all combustible materials and flammable vapors away from the brake resistors.



CAUTION: To prevent equipment damage, be certain that the input power has correctly sized protective devices installed.



CAUTION: To prevent equipment damage, be certain that input and output signals are powered and referenced correctly.



CAUTION: To ensure reliable performance of this equipment be certain that all signals to/from the drive are shielded correctly.



CAUTION: Suitable for use on a circuit capable of delivering not more than the RMS symmetrical short circuit amperes listed here at rated voltage.

<u>Horsepower</u>	<u>RMS Symmetrical Amperes</u>
1-50	5,000



CAUTION: Avoid locating the drive immediately above or beside heat generating equipment, or directly below water or steam pipes.



CAUTION: Avoid locating the drive in the vicinity of corrosive substances or vapors, metal particles and dust.



CAUTION: Do not connect AC power to the drive terminals U, V and W. Connecting AC power to these terminals may result in damage to the drive.



CAUTION: Baldor does not recommend using “Grounded Leg Delta” transformer power leads that may create earth/ground loops and degrade system performance. Instead, we recommend using a four wire Wye.



CAUTION: Drives are intended to be connected to a permanent main power source, not a portable power source. Suitable fusing and circuit protection devices are required.



CAUTION: The safe integration of the drive into a machine system is the responsibility of the machine designer. Be sure to comply with the local safety requirements at the place where the machine is to be used. In Europe these are the Machinery Directive, the ElectroMagnetic Compatibility Directive and the Low Voltage Directive. In the United States this is the National Electrical code and local codes.



CAUTION: Drives must be installed inside an electrical cabinet that provides environmental control and protection. Installation information for the drive is provided in this manual. Motors and controlling devices that connect to the drive should have specifications compatible to the drive.



CAUTION: Violent jamming (stopping) of the motor during operation may damage the motor and drive.



CAUTION: Do not tin (solder) exposed wires. Solder contracts over time and may cause loose connections. Use crimp connections where possible.



CAUTION: Electrical components can be damaged by static electricity. Use ESD (electro-static discharge) procedures when handling this drive.



CAUTION: Ensure that resolver or encoder wires are properly connected. Incorrect installation may result in improper movement.



CAUTION: The threaded holes in the top and bottom of the enclosure are for cable clamps. Be sure to use a M4 bolt no longer than 12mm in length. Longer bolts might short-circuit the electrical components inside the drive.



CAUTION: Removing the cover will invalidate UL certification.

2.1 FlexDrive^{II} features

Throughout this manual, both the FlexDrive^{II} and the Flex+Drive^{II} will be referred to simply as FlexDrive^{II}. Where there is a difference in specification it will be clearly marked.

The FlexDrive^{II} is a versatile compact control, providing a flexible and powerful solution for single axis rotary systems. Standard features include:

- Single axis AC brushless drive
- Wide range of models with continuous current ratings from 2.5A to 27.5A
- Direct connection to 115VAC or 230VAC single-phase or 230-460VAC three-phase supplies (model dependent)
- Resolver or encoder feedback
- Velocity and current control, with pulse and direction input for position control
- Auto-tuning wizard (including position loop) and software oscilloscope facilities
- 8 optically isolated digital inputs
- 3 optically isolated digital outputs
- 1 general-purpose analog input (can be used as a speed or torque command reference)
- 1 control relay
- Selectable RS232 or RS485 communications

Flex+Drive^{II} only:

- Integrated motion controller for rotary and linear positioning systems
- Programmable in Mint
- Up to 16 programmable preset moves (expandable to 256 with factory-fitted CAN and I/O option)
- Position control using preset moves, software gearing and point to point moves
- Flash memory for program storage (64k).
- Motion controller for rotary and linear positioning systems

Factory-fitted options expand the I/O capabilities of the FlexDrive^{II} and provide CANopen, DeviceNet or Profibus connectivity. See Appendix A for details about options. FlexDrive^{II} will operate with a large number of brushless servo motors - for information on selecting Baldor servo motors, please see the sales brochure BR1202 (BR1800 for linear motors) available from your local Baldor representative.

This manual is intended to guide you through the installation of FlexDrive^{II}. The sections should be read in sequence.

The *Basic Installation* section describes the mechanical installation of the FlexDrive^{II}, the power supply connections and motor connections. The other sections require knowledge of the low level input/output requirements of the installation and an understanding of computer software installation. If you are not qualified in these areas you should seek assistance before proceeding.

2.2 Receiving and inspection

When you receive your FlexDrive^{II}, there are several things you should do immediately:

1. Check the condition of the shipping container and report any damage immediately to the carrier that delivered your FlexDrive^{II}.
2. Remove the FlexDrive^{II} from the shipping container and remove all packing material. The container and packing materials may be retained for future shipment.
3. Verify that the catalog number of the FlexDrive^{II} you received is the same as the catalog number listed on your purchase order. The catalog number is described in the next section.
4. Inspect the FlexDrive^{II} for external damage during shipment and report any damage to the carrier that delivered your FlexDrive^{II}.
5. If FlexDrive^{II} is to be stored for several weeks before use, be sure that it is stored in a location that conforms to the storage humidity and temperature specifications shown in section 7.1.18.

2.2.1 Identifying the catalog number

The FlexDrive^{II} is available with different current ratings and package sizes. The catalog number is marked on the front of the unit, just below the Baldor logo. It is a good idea to look for the catalog number (sometimes shown as ID/No:) and write it in the space provided here:

Catalog number: **F_H** _____ - _____

Installed at: _____

Date: _____

A description of a catalog number is shown here, using the example **FDH1A05TB-RC23**:

	Meaning	Alternatives
FDH	FlexDrive ^{II} family	FPH =Flex+Drive ^{II}
1	Requires an AC supply voltage of 115 Volts, 1Φ	2 =230V (1Φ or 3Φ); 4 =230V-460V (3Φ)
A05	Continuous current rating of 5.0A	A02 =2.5A; A07 =7.5A; A15 =15A; A20 =20A; A27 =27.5A
T	Built in AC power supply	-
B	Dynamic Brake with a built in transistor and resistor (available on 2.5A and 5A models only)	R =Requires external braking resistor
R	Feedback option is a resolver	E =Encoder; D =EnDat (absolute encoder)
C	Option fitted: 1 CAN channel	B =CAN & Auxiliary I/O (Flex+Drive ^{II} only); D =DeviceNet; P =Profibus DP; N =No options specified
2	Serial port type is combined RS232 / RS485	-
3	Customer's own 24VDC supply is required to power the internal FlexDrive ^{II} logic	0 = Internally generated 24VDC supply*

* An external 24VDC supply will always be required to operate the enable input, digital inputs and digital outputs on connector X3 . See sections 4.3.1 to 4.3.5.

2.3 Units and abbreviations

The following units and abbreviations are used in this manual:

V Volt (also VAC and VDC)

W Watt

A Ampere

Ω Ohm

μ F microfarad

pF picofarad

mH millihenry

Φ phase

ms millisecond

μ s microsecond

ns nanosecond

Kbaud kilobaud (the same as Kbit/s in most applications)

MB megabytes

CDROM Compact Disc Read Only Memory

CTRL+E on the PC keyboard, press **Ctrl** then **E** at the same time.

mm millimeter

m meter

in inch

ft feet

lb-in pound-inch (torque)

Nm Newton-meter (torque)

ADC Analog to Digital Converter

DAC Digital to Analog Converter

AWG American Wire Gauge

(NC) Not Connected

3.1 Introduction

You should read all the sections in *Basic Installation* to ensure safe installation.

This section describes the mechanical and electrical installation of the FlexDrive^{II} in the following stages:

- Location considerations
- Mounting the FlexDrive^{II}
- Connecting the AC power supply
- Connecting the optional customer supplied 24VDC control supply
- Connecting the motor
- Installing a regeneration resistor (Dynamic Brake resistor)
- Connecting the feedback device
- Connecting the drive enable input.

These stages should be read and followed in sequence.

3.1.1 Power sources

An AC power source (IEC1010 over-voltage category III or less) in the installation area is required. This will need to be single or three-phase depending upon the type of FlexDrive^{II}. An AC power filter is required to comply with the CE directive for which the FlexDrive^{II} was tested (see section 3.4.5).

If the FlexDrive^{II} requires an external (customer supplied) 24VDC logic supply then this must be a regulated power supply with a continuous current supply capability of 1.75A (4A power on surge). A 24V filter may be required to comply with the CE directive for which the FlexDrive^{II} was tested (see section 3.4.5).

3.1.2 Hardware requirements

The components you will need to complete the basic installation are:

- The motor that will be connected to the FlexDrive^{II}
- A motor power cable
- A resolver or encoder feedback cable (and Hall cable for linear motors)
- With some applications there may be a requirement for a regeneration resistor (Dynamic Brake).

Note: Without the regeneration resistor, the drive may produce an overvoltage fault. All FlexDrive^{II} models have overvoltage sensing circuitry, but only 2.5A and 5A models (catalog numbers FDHxxxxxB-xxxx and FPHxxxxxB-xxxx) have an internal regeneration resistor. For 7.5A, 15A, 20A and 27.5A models a regeneration resistor must be purchased separately if required. See Appendix A.

- A serial cable.

Note: The serial connector on the FlexDrive^{II} (connector X6) can be configured as either RS232 or RS485 / RS422. Pin 9 is used to carry +8V for powering some Baldor keypad peripherals. Ensure that pin 9 is not connected to earth/ground or to equipment that could be damaged by the +8V supply. See sections 4.4.3 and 4.4.4. A suitable cable is available from Baldor, catalog number CBL001-501.

- A PC (with one free COM port) with the following specification:

	Minimum specification	Recommended specification
Processor	Intel Pentium 133MHz	Intel Pentium 200MHz or faster
RAM	32MB	64MB
Hard disk space	40MB	60MB
CD-ROM	A CD-ROM drive	
Screen	800 x 600, 256 colors	1024 x 768, 256 colors
Mouse	A mouse or similar pointing device	
Operating system	Windows 95, Windows 98, Windows ME, Windows NT, Windows XP or Windows 2000	

3.1.3 RS485 / RS422 systems

If you will be using RS485 / RS422 and your PC does not have an RS485 / RS422 connector, an RS232 to 4-wire RS485 / RS422 converter will be required. These commercially available devices convert the signals from the RS232/RS485 port (connector X6) to the signals necessary for RS485 / RS422 communications. Special care must be taken with the pin assignment on all RS485 / RS422 devices, as this can differ between products. Connectors might need to be rewired to provide the correct pin assignment. The FlexDrive^{II} pin assignment is shown in section 4.4.3.

Note: If this is the first time you are installing a FlexDrive^{II} then it is strongly recommended that you use RS232 to get started and try RS485 later. This will avoid any potential problems involving the RS232-RS485 converter. Selection of RS232 or RS485 is controlled using DIP switch 10 - see section 3.9.6.

3.1.4 Tools and miscellaneous hardware

- Your PC operating system user manual might be useful if you are not familiar with Windows
- A small screwdriver (supplied) with a blade width less than 3mm (1/10 in)
- M5 screws or bolts for mounting the FlexDrive^{II}
- Crimping tool.

A connector kit is supplied with your FlexDrive^{II}. This contains a number of useful connectors and a screwdriver for tightening the connections.

3.1.5 Other information needed for installation

This information is useful (but not essential) to complete the installation:

- The data sheet or manual provided with your motor, describing the wiring information of the motor cables/connectors
- Knowledge of which digital inputs/outputs will be 'Active Low', 'Active High' or edge triggered.

3.2 Mechanical installation and location requirements

It is essential that you read and understand this section before beginning the installation.



CAUTION: To prevent equipment damage, be certain that the input power has correctly rated protective devices installed.



CAUTION: To prevent equipment damage, be certain that input and output signals are powered and referenced correctly.



CAUTION: To ensure reliable performance of this equipment be certain that all signals to/from the FlexDrive^{II} are shielded correctly.



CAUTION: Avoid locating the FlexDrive^{II} immediately above or beside heat generating equipment, or directly below water steam pipes.



CAUTION: Avoid locating the FlexDrive^{II} in the vicinity of corrosive substances or vapors, metal particles and dust.

The safe operation of this equipment depends upon its use in the appropriate environment. The following points must be considered:

- The FlexDrive^{II} must be installed indoors, permanently fixed and located so that it can only be accessed by service personnel using tools.
- The maximum suggested operating altitude is 1000m (3300ft). Above 1000m (3300ft) de-rate output current 1.1% per 100m (330ft).
- The FlexDrive^{II} must operate in an ambient temperature of 0°C to 40°C (32°F to 104°F). De-rate output current 2.5% per 1°C (1.8°F) from 40°C (104°F) to 50°C (122°F) maximum.
- The FlexDrive^{II} must operate in relative humidity levels of less than 90% for temperatures up to 31°C (87°F) decreasing linearly to 50% relative humidity at 40°C (104°F) (non-condensing).
- The FlexDrive^{II} must be installed where the pollution degree according to IEC664 shall not exceed 2.
- The external customer supplied 24VDC for the logic supply must be installed so that the 24VDC supplied to the unit is isolated from the AC supply using double or reinforced insulation.
- The inputs and outputs of the control circuit must be limited to Safety Extra Low Voltage circuits.
- Both the AC supply and the external 24VDC supply must be fused.
- The atmosphere must not contain flammable gases or vapors.
- There must not be abnormal levels of nuclear radiation or X-rays.
- The FlexDrive^{II} must be secured by the slots in the flange, with the protective earth/ground stud bonded to a safety earth/ground by either a 25A conductor or a conductor of three times the peak current rating - whichever is the greater.

- For effective cooling and maintenance, the FlexDrive^{II} should be mounted on a smooth, non-flammable vertical surface. The power handling capability is affected by the temperature of the left side of the unit.
- At least 50mm (2 in) top and bottom clearance of the FlexDrive^{II} must be provided for airflow.
- If multiple FlexDrive^{II} are being mounted side by side there must be 13mm (0.5 in) between them. The FlexDrive^{II} nearest the side of the cabinet / enclosure must be separated from it by at least 13mm (0.5 in).
- To comply with CE directive 89/336/EEC an appropriate AC filter must be installed. The external customer supplied 24VDC logic supply might also require a 24V filter. See section 3.4.7.
- The threaded holes in the top and bottom of the enclosure are for cable clamps. The holes are threaded for M4 bolts no longer than 12mm (0.47 in) in length. Longer bolts may short circuit the electrical components inside the FlexDrive^{II}.
- Each D-type connector on the front panel of the FlexDrive^{II} is secured using two hexagonal jack screws (sometimes known as “screwlocks”). If a jack screw is removed accidentally or lost it must be replaced with an identical jack screw with an external male threaded section of 5mm (0.2 in). Jack screws with longer threads could damage or short circuit internal components.

3.2.1 Mounting the FlexDrive^{II}

Ensure you have read and understood the *Mechanical installation and location requirements* in section 3.2. Mount your FlexDrive^{II} on its rear side, the side opposite to the front panel. The FlexDrive^{II} must be mounted upright to ensure adequate cooling (you can check this by ensuring that the Hazardous Voltages warning information is clearly readable to you). M5 bolts or screws should be used to mount the FlexDrive^{II}.

There are seven different package sizes depending on the specification of the FlexDrive^{II} :

AC power	Current	Factory fitted option	Package size
Single-phase	2A	without option	A
		with option	B
	5A	without option	C
		with option	D
	7.5A	without option	D
		with option	D
230V Three-phase	15A	with or without option	E
230-460V Three-phase	2.5A, 5A, 7.5A	with or without option	G
	15A, 20A, 27.5A	with or without option	H

Detailed dimensions for each package are shown in section 3.2.2.

3.2.2 Dimensions

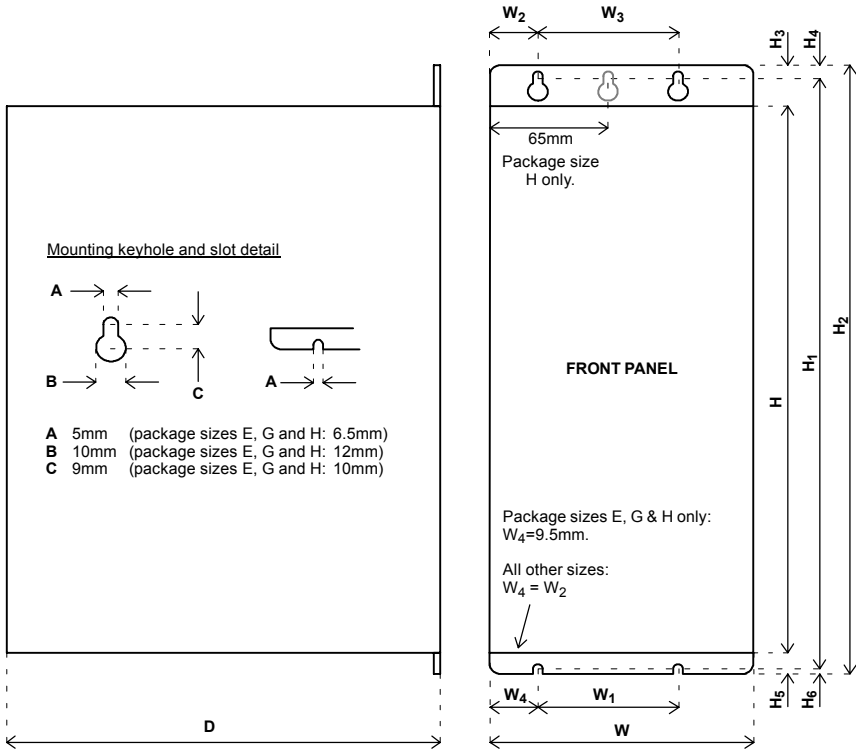

Case	Dimensions mm / inches												Weight kg / lb
	W	W ₁	W ₂	W ₃	H	H ₁	H ₂	H ₃	H ₄	H ₅	H ₆	D	
A	67.5 2.66	40 1.57	15 0.59	40 1.57	173 6.81	195.5 7.70	205 8.07	23.5 0.93	6.5 0.26	8.5 0.33	3 0.12	152 6.00	1.25 2.76
B	84 3.31												1.55 3.42
C	92.5 3.64		2.1 4.63										
D	109 4.29		2.3 5.07										
E	55 2.17	36 1.42	27.5 1.08	-	357 14.06	384 15.12	400 15.75	26.5 1.04	8 0.31	16.5 0.65	8 0.31	263.5 10.37	3.3 7.28
G	65 2.56	46 1.81	32.5 1.28	-								262 10.31	4.9 10.8
H	130 5.12	111 4.37	27.5 1.08	75 2.95								328 12.91	9.05 19.95

Figure 1 - Package dimensions

3.3 Connector locations

X1 / X1A Power

Single-phase models



- ⊕ Earth
- NC (NC)
- L AC Line
- N AC Neutral
- U Motor U
- V Motor V
- W Motor W
- R1 } Regen Resistor
- R2 } (Dynamic Brake)
- (NC)
- +24V Customer
- 0V } supplied 24V
- (FDHxxxxx-xxx3 /
- FPHxxxxx-xxx3)

Three-phase models, 230-460V



- ⊕ Earth
- ⊕ Earth
- L1 AC Phase 1
- L2 AC Phase 2
- L3 AC Phase 3
- U Motor U
- V Motor V
- W Motor W
- R1 } Regen Resistor
- R2 } (Dynamic Brake)
- +24V Customer supplied 24V
- 0V } (FDHxxxxx-xxx3 /
- FPH4xxxxx-xxx3)

Three-phase models, 230V



- ⊕ Earth
- ⊕ Earth
- L1 AC Phase 1
- L2 AC Phase 2
- L3 AC Phase 3
- U Motor U
- V Motor V
- W Motor W
- Vcc+ (NC)*
- Vcc- (NC)*
- R1 } Regen Resistor
- R2 } (Dynamic Brake)
- +24V Customer supplied 24V
- 0V } (FDH2xxxxx-xxx3 /
- FPH2xxxxx-xxx3)

* **Warning!** High voltages are present on terminals labeled Vcc+ and Vcc-. Do not make a connection to these terminals.

(NC) = Not Connected. Do not make a connection to this pin.

Tightening torque for terminal block connections is 0.5-0.6Nm (4.4-5.3 lb-in)

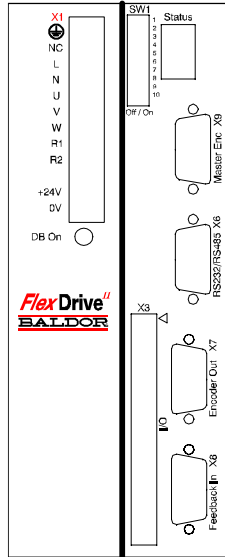

SW1 DIP switches



- 1 Node number
- 2 selection
- 3
- 4
- 5 (Reserved)
- 6 Hold
- 7 Offset tuning
- 8 Enable
- 9 (Reserved)
- 10 RS232/RS485

X3 General I/O



- 1 AIN0+ (Command+)
- 2 AIN0- (Command-)
- 3 AGND
- 4 Relay+
- 5 Relay-
- 6 User V+
- 7 CREF
- 8 CGND
- 9 Drive Enable
- 10 DIN0
- 11 DIN1
- 12 DIN2
- 13 DIN3
- 14 DIN4 (Pulse)
- 15 DIN5 (Direction)
- 16 DIN6
- 17 DIN7
- 18 DOUT0
- 19 DOUT1
- 20 DOUT2

X9 Master Encoder



- | Encoder | Pulse & Dir. |
|---------|----------------|
| 1 | CHA+ Pulse+ |
| 2 | CHB+ Dir.+ |
| 3 | CHZ+ (NC) |
| 4 | (NC) (NC) |
| 5 | DGND (NC) |
| 6 | CHA- Pulse GND |
| 7 | CHB- Dir. GND |
| 8 | CHZ- (NC) |
| 9 | +5V (NC) |

X6 RS232/RS485



- | RS232 | RS485/422 |
|-------|--------------------------|
| 1 | (NC) (NC) |
| 2 | RXD RX- |
| 3 | TXD TX- |
| 4 | (NC) (NC) |
| 5 | 0V GND 0V DGND |
| 6 | (NC) (NC) |
| 7 | RTS TX+ |
| 8 | CTS RX+ |
| 9 | (NC - see section 4.4.3) |

X7 Encoder Out



- 1 CHA+
- 2 CHB+
- 3 CHZ+
- 4 (NC)
- 5 DGND
- 6 CHA-
- 7 CHB-
- 8 CHZ-
- 9 (NC)

X8 Feedback In



- Resolver option**
- 1 REF+
 - 2 COS+
 - 3 SIN+
 - 4 (NC)
 - 5 AGND
 - 6 REF-
 - 7 COS-
 - 8 SIN-
 - 9 Chassis

Encoder options



- | Incremental | EnDat |
|-------------|----------------|
| 1 | CHA+ Data+ |
| 2 | CHB+ Data- |
| 3 | CHZ+ (NC) |
| 4 | Hall U+ +5V |
| 5 | Hall U- DGND |
| 6 | CHA- Shield |
| 7 | CHB- Cos B- |
| 8 | CHZ- (NC) |
| 9 | Hall W+ Clock- |
| 10 | Hall V+ Clock+ |
| 11 | +5V DGND |
| 12 | (NC) Sin A- |
| 13 | DGND Sin A+ |
| 14 | Hall W- Cos B+ |
| 15 | Hall V- (NC) |

Options:

If there are other connectors on the front panel of your FlexDrive^{II}, then an option is fitted. See the other manuals supplied with your FlexDrive^{II}.

3.4 Power connections

This section provides instructions for connecting the AC power supply. It is important that you refer to the correct front panel for your FlexDrive^{II} package.

The installer of this equipment is responsible for complying with NEC (National Electric Code) guidelines or CE (Conformite Europeene) directives and application codes that govern wiring protection, earthing/grounding, disconnects and other current protection.



WARNING: Electrical shock can cause serious or fatal injury. Do not touch any power device or electrical connection before you first ensure that power has been disconnected and there is no high voltage present from this equipment or other equipment to which it is connected.

The power supply module within all FlexDrive^{II} models provides rectification, smoothing and current surge protection. On 2.5A and 5A models a regeneration resistor (Dynamic Brake resistor) is also built-in. The power stage is internally fused and therefore self protected, but fuses or circuit breakers are required in the input lines for cable protection (depending on local codes and regulations).

A power disconnect should be installed between the AC supply and the input of the FlexDrive^{II} for a fail safe method to disconnect power. On models with the internally generated 24VDC logic supply (catalog numbers FDHxxxxx-xxx0 and FPHxxxxx-xxx0), the FlexDrive^{II} will remain operational until the internal bus voltage is depleted. Position and I/O information will then be lost. On models with an external customer supplied 24VDC logic supply (catalog numbers FDHxxxxx-xxx3 and FPHxxxxx-xxx3), position and I/O information will be retained while the 24V supply is present.

Note: A Residual Current Device (RCD) must not be used for fusing the drive. A circuit breaker or fuse must be used.

All interconnection wires should be in metal conduits between the FlexDrive^{II}, AC power source, motor, host controller and any operator interface stations. Use UL listed closed loop connectors that are of appropriate size for the wire gauge being used. Connectors are to be installed using only the crimp tool specified by the manufacturer of the connector. Only class 1 wiring should be used.

Baldor drives are designed to be powered from standard single and three-phase lines (depending on model) that are electrically symmetrical with respect to earth/ground. Due to the importance of system earthing/grounding for increased reliability, earthing/grounding methods are shown in sections 3.4.1 and 3.4.2.

Note: When using unearthed/ungrounded distribution systems, an isolation transformer with an earthed/grounded secondary is recommended. This provides three-phase AC power that is symmetrical with respect to earth/ground and can prevent equipment damage.

3.4.1 Single-phase connection to package sizes A, B, C, D

Location	Connector X1 (Mating connector: Phoenix COMBICON MVSTBW 2,5/9-ST, 5mm pitch)	
Part number	FDH1A... / FPH1A...	FDH2A... / FPH2A...
Nominal input voltage	115VAC, 1 Φ line to neutral	230VAC, 1 Φ line to neutral
Range	97-125VAC	220-250VAC

For single-phase connection, the voltage ripple on the DC-bus is 25Vp-p for 5A peak current rising to 50Vp-p for 10A peak current. This can limit the maximum speed of the motor. Tightening torque for terminal block connections is 0.5-0.6Nm (4.4-5.3 lb-in).

The threaded hole in the top of the enclosure is for protective earth/ground connections. The threaded hole in the bottom of the enclosure may be used as an additional functional earth/ground connection for signals on connector X3. It may also be used to attach strain relief clamps. The holes are threaded for M4 bolts no longer than 12mm (0.47 in) in length. Longer bolts may short circuit the electrical components inside the FlexDrive^{II}.

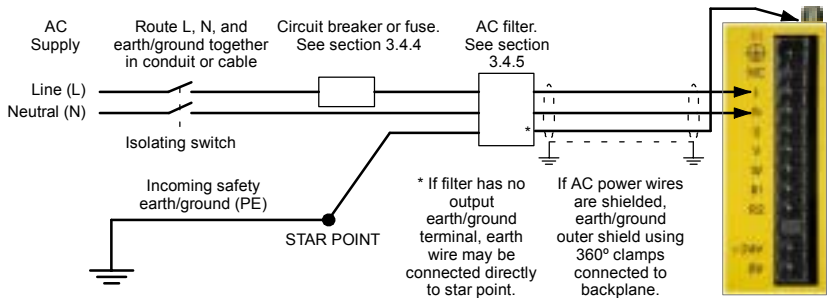

Figure 2 - Earthing/grounding for single-phase installations

Note: For CE compliance, a filter must be connected between the AC power supply and the FlexDrive^{II}. If local codes do not specify different regulations, use at least the same gauge wire for earth/ground as is used for L and N.

3.4.2 Three-phase connection to package sizes E, G, H

Location	Connector X1A (Mating connector: Phoenix POWER COMBICON PC4/..-ST- 7.62)	
Part number	FDH2A15... / FPH2A15...	FDH4A... / FPH4A...
Nominal input voltage	230VAC, 3 Φ line to line	230-460VAC, 3 Φ line to line
Range	184-253VAC	180-528VAC

Tightening torque for terminal block connections is 0.5-0.6Nm (4.4-5.3 lb-in). The threaded hole in the top of the enclosure is for protective earth/ground connections. The threaded hole in the bottom of the enclosure (if present) may be used as an additional functional earth/ground connection for signals on connector X3. It may also be used to attach strain relief clamps. The holes are threaded for M4 bolts no longer than 12mm (0.47 in) in length. Longer bolts may short circuit the electrical components inside the FlexDrive^{II}.

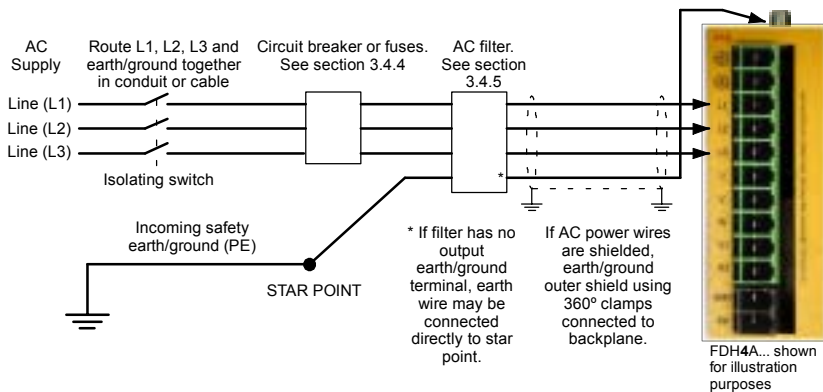

Figure 3 - Earthing/grounding for three-phase installations



WARNING: Drives with part numbers FDH2A15... or FPH2A15... have two additional terminals on the X1 connector labeled Vcc+ and Vcc-. The full output bus voltage is present on these terminals so do not make any connection to them.

Note: For CE compliance, a three-phase AC filter must be connected between the AC power supply and the FlexDrive^{II}. If local codes do not specify different regulations, use at least the same gauge wire for earth/ground as is used for L and N.

3.4.3 Input power conditioning

Baldor drives are designed for direct connection to standard single and three-phase lines (depending on model) that are electrically symmetrical with respect to earth/ground. Certain power line conditions must be avoided; an AC line reactor, an isolation transformer or a step up/step down transformer may be required for some power conditions:

- If the feeder or branch circuit that provides power to the FlexDrive^{II} has permanently connected power factor correction capacitors, an input AC line reactor or an isolation transformer must be connected between the power factor correction capacitors and the FlexDrive^{II}.
- If the feeder or branch circuit that provides power to the FlexDrive^{II} has power factor correction capacitors that are switched on line and off line, the capacitors must not be switched while the drive is connected to the AC power line. If the capacitors are switched on line while the drive is still connected to the AC power line, additional protection is required. A Transient Voltage Surge Suppressor (TVSS) of the proper rating must be installed between the AC line reactor (or isolation transformer) and the AC input to the FlexDrive^{II}.

3.4.3.1 Input power-cycling

If AC power has been removed from the FlexDrive^{II}, it should not be reapplied for at least one minute. This delay allows the input surge protection circuit to perform correctly. Power-cycling the drive more frequently could cause nuisance trips when power is reapplied and reduce the lifetime of the FlexDrive^{II}.

3.4.4 Power disconnect and protection devices

A power disconnect should be installed between the input power service and the FlexDrive^{II} for a fail-safe method to disconnect power. The FlexDrive^{II} will remain in a powered condition until all input power is removed from the drive and the internal bus voltage has depleted.

The FlexDrive^{II} must have a suitable input power protection device installed. Recommended circuit breakers are thermal magnetic devices (1 or 3 phase as required) with characteristics suitable for heavy inductive loads (D-type trip characteristic). Recommended time delay fuses are Buss FRN on 230VAC or equivalent, following the UL 508C recommendation of a fuse size of four times the continuous output current of the drive. Dual element, time delay fuses should be used to avoid nuisance trips due to inrush current when power is first applied.

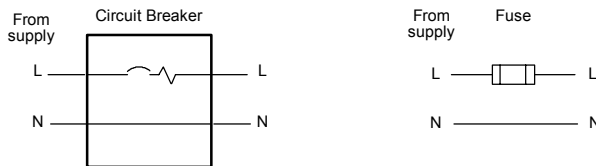

Figure 4 - Circuit breaker and fuse, single-phase (package sizes A, B, C, D)

Note: Power to single phase models may be derived by connecting two phases of an appropriate three-phase supply (L1 and L2 for example). When supplying AC power in this way, the voltage between the two phases must not exceed the rated input voltage of the FlexDrive^{II}. A two pole breaker must be used to isolate both lines. Fuses must be fitted in both lines. Circuit breaker or fuse are not supplied. For CE compliance, see Appendix C.

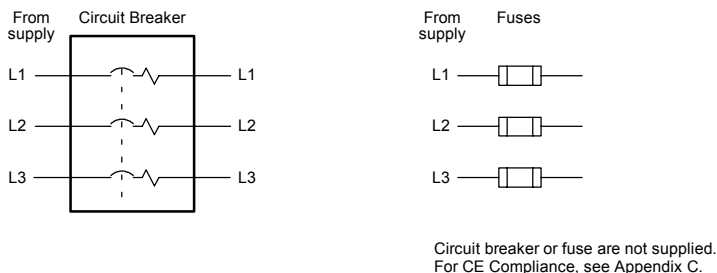

Figure 5 - Circuit breaker and fuse, three-phase (package sizes E, G, H)

Note: Metal conduit or shielded cable should be used. Connect conduits so the use of a line reactor or RC device does not interrupt EMI/RFI shielding.

3.4.5 Power supply filters

To comply with EEC directive 89/336/EEC, an AC power filter of the appropriate type must be connected. This can be supplied by Baldor and will ensure that the FlexDrive^{II} complies with the CE specifications for which it has been tested. Table 1 lists the appropriate filters:

FlexDrive ^{II} current rating	Input voltages			
	115VAC, 1Φ	230VAC, 1Φ	230VAC, 3Φ	230-460VAC, 3Φ
2.5A	FI0014A00	FI0019A00		FI0018A00
5A	FI0015A00	FI0015A00		FI0018A00
7.5A	FI0015A01	FI0015A01*		FI0018A00
15A			FI0018A01	FI0018A01
20A			FI0018A01	
27.5A			FI0018A01	

Table 1 - Baldor filter part numbers

* If this model requires a customer supplied 24V control supply (catalog numbers FDH2A07Tx-xxx3 or FPH2A07Tx-xxx3), use filter FI0015A02. For further details of power supply filters see section A.1.6.

3.4.6 Wire sizes and protection device ratings

Table 2 describes the wire size to be used for power connections and the ratings of the protection devices.

Catalog Number	Incoming Power					
	Nominal Input Voltage	Continuous Output Amps (RMS)	D-Type Input Breaker (A)	Time Delay Input Fuse (A)	Minimum Wire Gauge	
					AWG	mm ²
FDH1A02xx-xxxx FPH1A02xx-xxxx	115V (1Φ)	2.5A	6	6	14	2.0
FDH2A02xx-xxxx FPH2A02xx-xxxx	230V (1Φ)	2.5A	6	6	14	2.0
FDH1A05xx-xxxx FPH1A05xx-xxxx	115V (1Φ)	5A	10	10	14	2.0
FDH2A05xx-xxxx FPH2A05xx-xxxx	230V (1Φ)	5A	10	10	14	2.0
FDH1A07xx-xxxx FPH1A07xx-xxxx	115V (1Φ)	7.5A	16	16	14	2.0
FDH2A07xx-xxxx FPH2A07xx-xxxx	230V (1Φ)	7.5A	16	16	14	2.0
FDH4A02xx-xxxx FPH4A02xx-xxxx	230-460V (3Φ)	2.5A	6	6	14	2.0
FDH4A05xx-xxxx FPH4A05xx-xxxx	230-460V (3Φ)	5A	10	10	14	2.0
FDH4A07xx-xxxx FPH4A07xx-xxxx	230-460V (3Φ)	7.5A	16	16	14	2.0
FDH2A15xx-xxxx FPH2A15xx-xxxx	230V (3Φ)	15A	32	32	12	3.3
FDH4A15xx-xxxx FPH4A15xx-xxxx	230-460V (3Φ)	15A	32	32	12	3.3
FDH4A20xx-xxxx FPH4A20xx-xxxx	230-460V (3Φ)	20A	40	40	10	5.3
FDH4A27xx-xxxx FPH4A27xx-xxxx	230-460V (3Φ)	27.5A	60	60	10	5.3

Table 2 - Protection device and wire ratings

Note: All wire sizes are based on 75°C (167°F) copper wire. Higher temperature smaller gauge wire may be used per National Electric Code (NEC) and local codes. Recommended fuses/breakers are based on 25°C (77°F) ambient, maximum continuous control output current and no harmonic current. Earth/ground wires must be the same gauge, or larger, than the Line and Neutral wires.

3.4.7 External customer supplied 24V control supply

Depending on model (catalog numbers FDHxxxxx-xxx3 and FPHxxxxx-xxx3) a 24VDC control supply must be provided to power the control electronics. This is useful for safety reasons where AC power needs to be removed from the power stage but the control electronics must remain powered to retain position and I/O information. It is recommended that a separate fused 24V supply is provided for the FlexDrive^{II}. If other devices are likely to be powered from the same 24V supply then a filter (Baldor catalog number F10014A00) should be installed to isolate the FlexDrive^{II} from the rest of the system.

Location	Connector X1 / X1A
Part number	FDHxxxxx-xxx3 or FPHxxxxx-xxx3
Nominal input voltage	24V
Range	20.4-28.8VDC
Input current (maximum)	1.75A continuous (4A power on surge)

Tightening torque for terminal block connections is 0.5-0.6Nm (4.4-5.3 lb-in)

Note: Connect 24V to connector X1 only if your model has this feature. Connecting 24V to a model that does *not* require an external 24V supply (FDHxxxxx-xxx0 and FPHxxxxx-xxx0) could damage the unit.

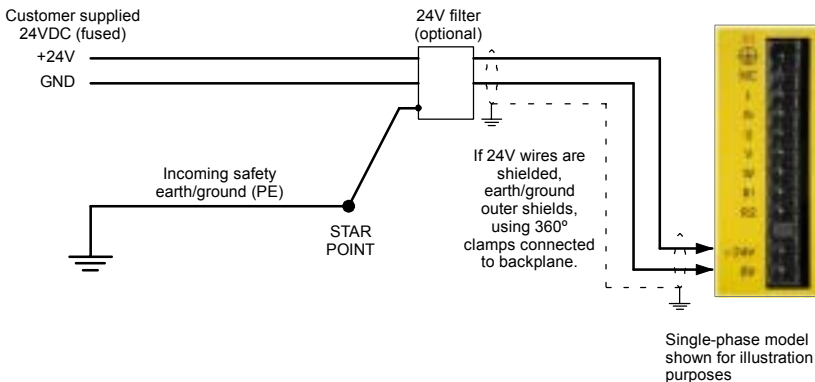

Figure 6 - Customer supplied 24V supply connections

3.5 Motor connections

The motor can be connected directly to the FlexDrive^{II} or through a motor contactor (M-Contactor).

Location	Connector X1 / X1A			
Part number	FDH1A... FPH1A...	FDH2A... FPH2A...	FDH2A15... FPH2A15...	FDH4A... FPH4A...
Nominal output voltage	160VDC	320VDC	320VDC	565/650V
Output voltage range	135-176VDC	306-350VDC	258-355VDC	254-746VDC

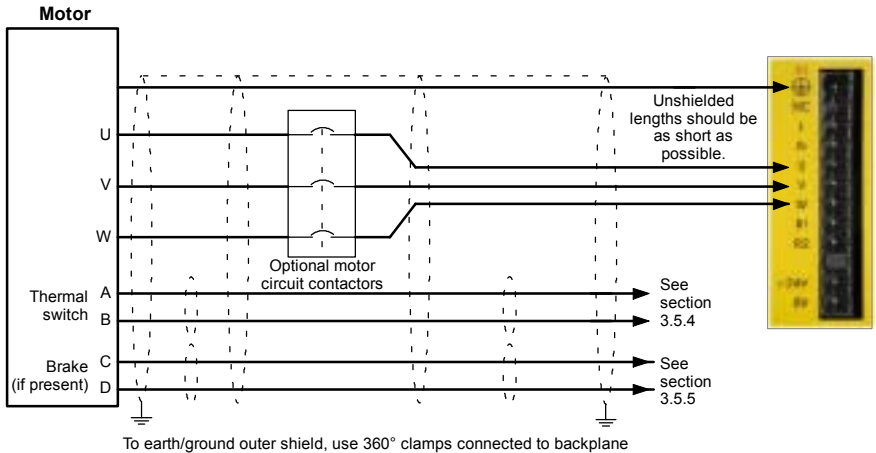

Figure 7 - Motor connections

CAUTION: Do not connect supply power to the FlexDrive^{II} UVW outputs. The FlexDrive^{II} might be damaged.

CAUTION: The motor leads U, V and W must be connected to their corresponding U, V or W terminal on the motor. Misconnection will result in uncontrolled motor movement.

The motor power cable must be shielded for CE compliance. The connector or gland used at the motor must provide 360 degree shielding. The maximum recommended cable length is 30.5m (100ft).

Note: For CE compliance the motor earth/ground should be connected to the drive earth/ground.

3.5.1 Motor circuit contactors

If required by local codes or for safety reasons, an M-Contactor (motor circuit contactor) may be installed to provide a physical disconnection of the motor windings from the FlexDrive^{II} (see section 3.5). Opening the M-Contactor ensures that the FlexDrive^{II} cannot drive the motor, which may be necessary during equipment maintenance or similar operations. Under certain circumstances, it may also be necessary to fit a brake to a rotary motor. This is important with hanging loads where disconnecting the motor windings could result in the load falling. Contact your local supplier for details of appropriate brakes.



CAUTION: If an M-Contactor is installed, the FlexDrive^{II} must be disabled at least 20ms before the M-Contactor is opened. If the M-Contactor is opened while the FlexDrive^{II} is supplying voltage and current to the motor, the FlexDrive^{II} may be damaged. Incorrect installation or failure of the M-Contactor or its wiring may result in damage to the FlexDrive^{II}.

Ensure that shielding of the motor cable is continued on both sides of the contactor.

3.5.2 Motor power cable pin configuration - Baldor BSM rotary motors

Figure 8 shows the pin configuration for a typical Baldor motor cable, part number CBL030SP-MHCE:

Signal name	Motor / cable pin	Motor cable wire color
Motor U	1	Black, labeled '1'
Motor V	4	Black, labeled '2'
Motor W	3	Black, labeled '3'
Earth/ground	2	Green/Yellow
Thermal switch	A	Green
Thermal switch	B	White
Brake	C	Blue
Brake	D	Red

Note:
Not all motors are fitted with a brake so pins C and D might not be connected.

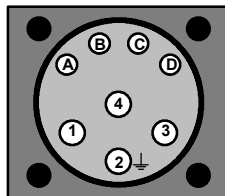

Motor power connector (male)

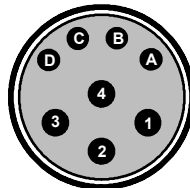

Cable connector end view (female)

Figure 8 - Baldor motor power cable pin configuration

3.5.3 Motor cable pin configuration - Baldor linear motors

The following table shows the pin colors used in a typical Baldor linear motor cable set, part number AY1763A00:

Signal name	Motor cable wire color
Motor U	Black
Motor V	Red
Motor W	White
Motor ground	Green
Thermal switch	Blue
Thermal switch	Orange

Signal name	Hall cable wire color
Hall 1 (U)	White
Hall 2 (V)	Red
Hall 3 (W)	Black
Hall ground	Green
Hall +5VDC	Brown

3.5.4 Thermal switch connection

You might wish to wire the motor's thermal switch contacts (normally open), using a relay, to a digital input on connector X3 (see section 4.3.1). Using the WorkBench v5 Digital I/O tool, the input can be configured to be the motor trip input. This allows the FlexDrive^{II} to respond to motor over-temperature conditions. The Mint keyword `MOTORTEMPERATUREINPUT` can also be used to configure a digital input for this purpose. A typical circuit, using DIN1 as the input, is shown in Figure 9.

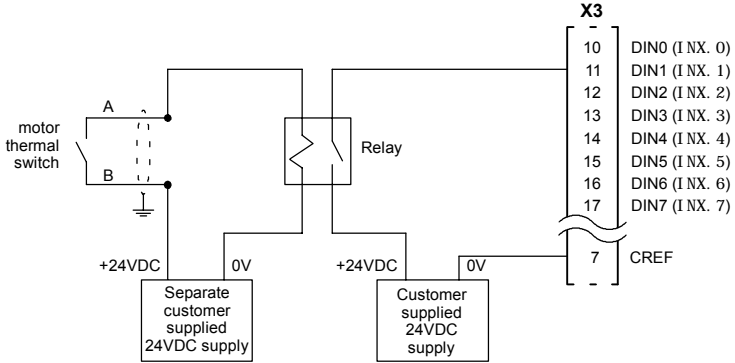

Figure 9 - Motor thermal switch circuit



CAUTION: The 24VDC power supply connected to the thermal switch must be a separate supply as shown in Figure 9. Do not use the 24V supply used for the drive enable signal, or the internally generated supply (if present). The thermal switch wires often carry noise that could cause erratic drive operation or damage. The thermal switch contacts must never be wired directly to a digital input.

The separate 24VDC supply used for the thermal switch may also be used for the motor brake circuit (section 3.5.5).

3.5.5 Motor brake connection

You might wish to wire a motor's brake, via relays, to digital outputs on connector X3 (see section 4.3.1). This provides a way for the Mint program to control the motor's brake. A typical circuit is shown in Figure 10.

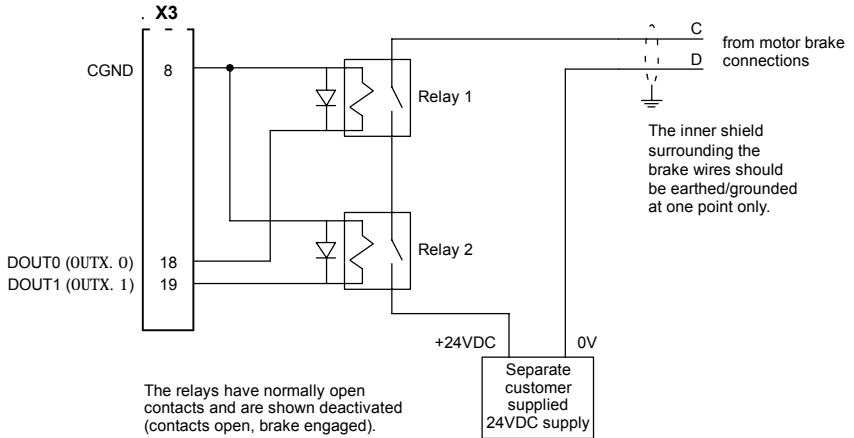

Figure 10 - Motor brake control circuit

This circuit uses the drive enable signal (configured using DRI VEENABLEOUTPUT to appear on DOUT0) in conjunction with DOUT1. With this configuration, the following sequences can be used to control the brake.

To engage the brake:

- The motor is brought to rest under normal control;
- Relay 2 is deactivated, causing the brake to engage;
- The drive is disabled. This removes power from the motor and causes Relay 1 to be deactivated.

To disengage the brake:

- The drive is enabled, activating Relay 1;
- Power is applied to the motor to hold position under normal control;
- Relay 2 is activated, causing the brake to be disengaged.



CAUTION: The 24VDC power supply must be a separate supply as shown in Figure 10. Do not use the 24V supply powering the FlexDrive^{II} digital outputs, or the internally generated supply (if present). The brake wires often carry noise that could cause erratic drive operation or damage. The brake contacts must never be wired directly to the digital outputs. The relay(s) should be fitted with a protective flyback diode, as shown.

The separate 24VDC supply used for the motor brake may also be used to power the relay in the thermal switch circuit (section 3.5.4).

3.6 Regeneration resistor (Dynamic Brake resistor)

The 2.5A and 5A FlexDrive^{II} both have an internally fitted regeneration resistor *. For 7.5A, 15A, 20A and 27.5A FlexDrive^{II}, an external regeneration resistor must be installed to dissipate excess power from the internal DC bus during motor deceleration.

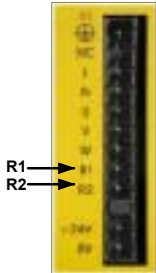

Suitable regeneration resistors are listed in section A.1.7.



WARNING: A regeneration resistor may generate enough heat to ignite combustible materials. To avoid fire hazard, keep all combustible materials and flammable vapors away from the resistors.

The regeneration resistor should be mounted near the top of an enclosure to maximize heat dissipation. When the motor regenerates, the yellow **DB On** LED on the front panel of the FlexDrive^{II} will illuminate.

* If required by the application, additional external resistors connected to R1 and R2 will be connected in parallel with the internal resistor.

3.6.1 Controlling regeneration

Some regeneration resistor assemblies include an overload switch to indicate when too much power is being dissipated by the resistor. This switch can be wired to a digital input on the FlexDrive^{II}. Using the WorkBench v5 Digital I/O tool, the input can be configured to be the brake trip input. This allows the FlexDrive^{II} to respond to resistor overload conditions.

The Mint keyword `DBEXTTRI INPUT` can also be used to configure a digital input for this purpose. On three-phase FlexDrive^{II} models, the operation of the regeneration resistor can be controlled by further Mint keywords. These also begin with the letters `DB...`, for example `DBEXTPEAKPOWER`. See the Mint help file for details.

3.7 Feedback connections

Two feedback options are available for use with linear and rotary motors - commutating encoder or resolver. Confirm the catalog number of your FlexDrive^{II} (see section 2.2.1) to ensure you are wiring the correct feedback device. There are some important considerations when wiring the feedback device:

- The feedback device wiring must be separated from power wiring.
- Where feedback device wiring runs parallel to power cables, they must be separated by at least 76mm (3 in)
- Feedback device wiring must cross power wires at right angles only.
- To prevent contact with other conductors or earths/grounds, unearthed/ungrounded ends of shields must be insulated.
- Some larger D-type connector shells may be obstructed by neighboring connector X3.
- Linear motors use two separate cables (encoder and Hall). The cores of these two cables will need to be wired to the appropriate pins of the 15-pin D-type mating connector (supplied).

An encoder output signal is available on connector X7 for supplying other equipment. FlexDrive^{II} models with the resolver option provide a simulated encoder output, while the encoder based FlexDrive^{II} duplicates the encoder signals entering X8. See section 4.4.1 for details.

3.7.1 Resolver option - X8

The resolver connections are made using the 9-pin D-type male connector X8. Twisted pair cables must be used for the complementary signal pairs e.g. SIN+ and SIN-. The overall cable shield (screen) must be connected to the metallic shell of the D-type connector.

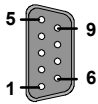

Location	Connector X8, 9-pin D-type male connector
Pin	Resolver function
1	REF+
2	COS+
3	SIN+
4	(NC)
5	Analog Ground
6	REF-
7	COS-
8	SIN-
9	Chassis Ground
Description	Resolver input with 14-bit resolution

The resolver input is used to create an encoder signal inside the FlexDrive^{II}. This provides the FlexDrive^{II} with an equivalent resolution of 4096 pulses per revolution (ppr), although this can be reconfigured in the WorkBench v5 Commissioning Wizard to provide 1024 ppr. The FlexDrive^{II} provides an input accuracy of ± 3 counts. When used with a typical Baldor BSM series resolver motor the combined accuracy is ± 11 counts (calculated with the input equivalent resolution set to the factory preset value of 4096 ppr).

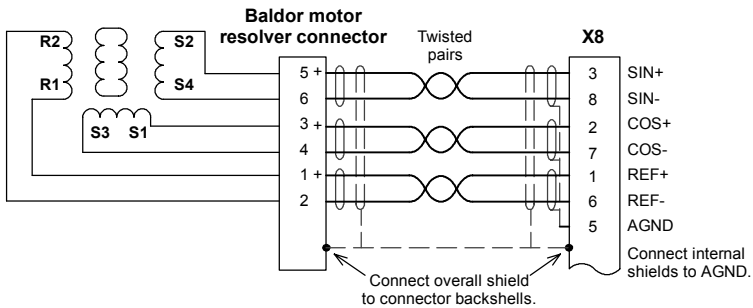

Figure 11 - Resolver cable connections

3.7.1.1 Resolver cable pin configuration

Figure 12 shows the pin configuration for a typical Baldor resolver feedback cable, part number CBL030SF-ALCE.

Signal name	FlexDrive ^{II} X8 pin	Motor / cable pin	Baldor resolver cable internal wire colors
REF+	1	1	Red
REF-	6	2	Blue
COS+	2	3	Green
COS-	7	4	Yellow
SIN+	3	5	Pink
SIN-	8	6	Grey

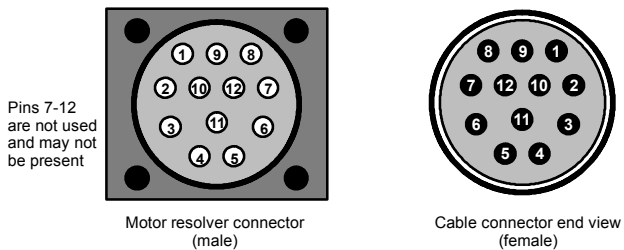
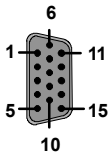

Figure 12 - Baldor motor resolver cable pin configuration

The maximum recommended cable length is 30.5m (100ft).

3.7.2 Encoder option - X8

The encoder connections (ABZ channels and Hall signals) are made using the 15-pin D-type female connector X8. Twisted pair cables must be used for the complementary signal pairs e.g. CHA+ and CHA-. The overall cable shield (screen) must be connected to the metallic shell of the D-type connector.



Location	Connector X8, 15-pin D-type female connector
Pin	Encoder function
1	CHA+
2	CHB+
3	CHZ+
4	Hall U+
5	Hall U-
6	CHA-
7	CHB-
8	CHZ-
9	Hall W+
10	Hall V+
11	+5V out
12	(NC)
13	DGND
14	Hall W-
15	Hall V-
Description	Commutating (UVW) encoder input, non-isolated. Pin 11 provides +5V for encoders requiring power (200mA max)

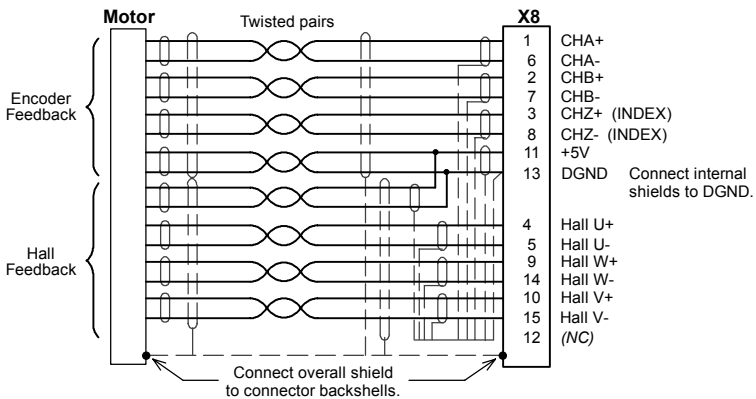

Figure 13 - Encoder cable connections - rotary motors

3.7.2.1 Encoder cable pin configuration - rotary motors

Figure 14 shows the pin configuration for a typical Baldor encoder feedback cable, part number CBL030SF-KPCEA3.

Signal name	FlexDrive ^{II} X8 pin	Motor / cable pin
CHA+	1	3
CHA-	6	4
CHB+	2	5
CHB-	7	6
CHZ+	3	7
CHZ-	8	8
Hall U+	4	10
Hall U-	5	11
Hall V+	10	12
Hall V-	15	13
Hall W+	9	14
Hall W-	14	15
+5V	11	1
DGND	13	2

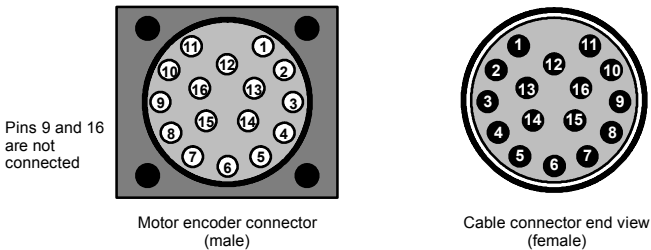

Figure 14 - Baldor rotary motor encoder cable pin configuration

The maximum recommended cable length is 30.5m (100ft).

3.7.2.2 Encoder cable connections - linear motors

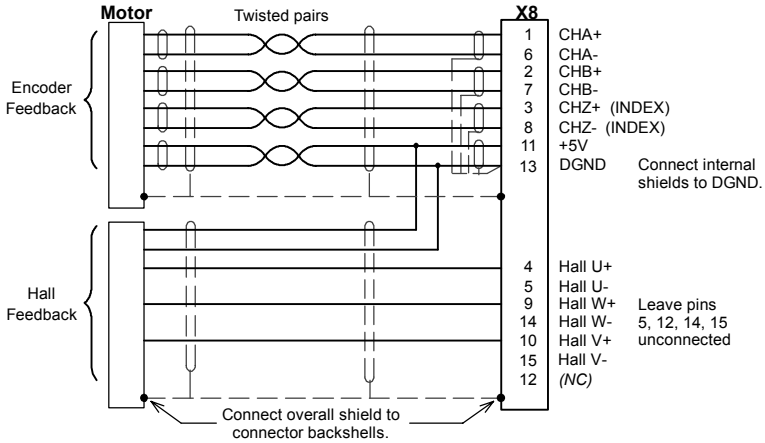

Figure 15 - Encoder cable connections - linear motors

3.7.2.3 Encoder cable pin configuration - linear motors

Linear motors use two separate cables (encoder and Hall). The cores of these two cables must be wired to the appropriate pins of the 15-pin D-type mating connector (supplied):

Signal name	FlexDrive ^{II} X8 pin	Encoder cable internal wire colors
CHA+	1	Please refer to MN1800 <i>Linear Motors Installation & Operating Manual</i> for details.
CHA-	6	
CHB+	2	
CHB-	7	
CHZ+	3	
CHZ-	8	
		Baldor Hall cable internal wire colors
Hall U+	4	White
Hall V+	10	Red
Hall W+	9	Black
+5V	11	Brown
Hall GND	13	Green

3.7.3 EnDat (absolute encoder) option - X8

The absolute encoder interface supports both incremental and absolute (multi and single turn) feedback using SinCos technology. It is possible to read and write information to the encoder. The absolute encoder connections are made using the 15-pin D-type female connector X8. Twisted pair cables must be used for the complementary signal pairs e.g. SinA+ and SinA-. The overall cable shield (screen) must be connected to the metallic shell of the D-type connector.



Location	Connector X8, 15-pin D-type female connector
Pin	Encoder function
1	Data+
2	Data-
3	<i>(Reserved - do not connect)</i>
4	+5V
5	DGND
6	Shield
7	Cos B-
8	<i>(Reserved - do not connect)</i>
9	Clock-
10	Clock+
11	<i>(Reserved - do not connect)</i>
12	Sin A-
13	Sin A+
14	Cos B+
15	<i>(Reserved - do not connect)</i>
Description	Absolute encoder input, non-isolated. Pin 4 provides power to the encoder (200mA max)

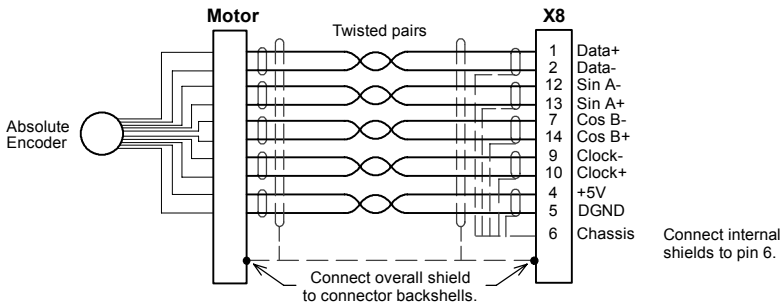
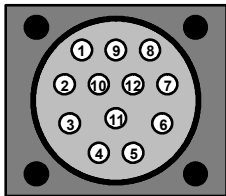

Figure 16 - Absolute encoder cable connections

3.7.3.1 Absolute encoder cable pin configuration

Figure 17 shows the pin configuration for a typical Baldor absolute encoder feedback cable, part number CBL030SF-KLCEA3.

Signal name	FlexDrive ^{II} X8 pin	Motor / cable pin
Data -	2	1
Sin A+	13	2
Cos B+	14	4
Clock-	9	5
Clock +	10	7
Cos B-	7	8
+5V	4	9
DGND	5	10
Sin A-	12	11
Data +	1	12



Motor absolute encoder connector
(male)

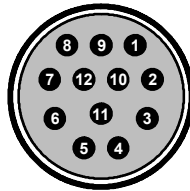

Cable connector end view
(female)

Figure 17 - Baldor rotary motor absolute encoder cable pin configuration

The maximum recommended cable length is 30.5m (100ft).

3.8 Drive enable - X3

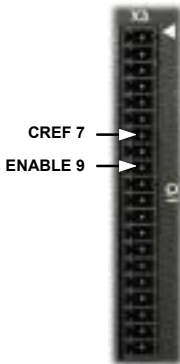

Location	Connector X3, pins 7 & 9 (Mating connector: Phoenix MINI-COMBICON MC 1.5/20-ST-3,5)
Name	Drive enable
Input voltage	+24VDC ($\pm 20\%$)

To enable the FlexDrive^{II} and allow motion, three actions are necessary:

- A customer supplied externally generated 24VDC supply must be connected between pins 7 and 9.
- The drive enable DIP switch (switch 8) must be in the On position.
- A drive enable command must be received.

These actions are explained in the following sections.

3.8.1 Drive enable - X3

The wiring to the drive enable input can be connected in one of two ways. Because CREF is common to all the digital inputs, this has an effect on the sense of DIN0 to DIN7. Either method provides a suitable drive enable input:

Active high

To cause the digital inputs to be active high (active when a voltage of +24VDC is applied to them) connect +24VDC to pin 9 and 0V to pin 7 (CREF).

Active low

To cause the digital inputs to be active low (active when grounded) connect +24VDC to pin7 (CREF) and 0V to pin 9.

The drive enable connection can be wired directly or through an intermediate switch. If a switch is used it should always be used to switch the signal to pin 9, with the signal to pin 7 (CREF) being hard-wired.

The sense of the digital inputs can also be configured in WorkBench v5 using the Digital inputs tab of the Digital I/O tool. Alternatively, the Mint INPUTACTI VELEVEL keyword can be used to select the sense of all the digital inputs (except drive enable).

The state of the drive enable input is displayed in the WorkBench v5 Spy window. It can also be checked (but not set) using the Mint keyword DRI VEENABLESWI TCH. See the Mint help file for details.

3.8.2 Drive enable - SW1 DIP switch

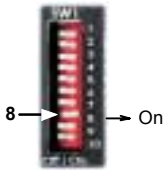

To enable the FlexDrive^{II} the front panel DIP switch 8 must be set to On. This switch provides a local enable/disable switch that can be useful during testing.

The state of the drive enable DIP switch is displayed in the WorkBench v5 Spy window. It can also be checked (but not set) using the Mint keyword ENABLESWITCH. See the Mint help file for details.

See section 3.9 for full details of other DIP switch functions.

3.8.3 Drive enable command

The other action required to enable the FlexDrive^{II} can be controlled either by software or hardware.

Note: This method is explained here for your information, but cannot be completed until you have installed the software and are ready to turn on AC power to the drive. Please continue to read all sections in sequence. Do not turn on AC power until you reach the appropriate instructions.

In software, a drive enable command must be issued. The easiest way to do this is by clicking the Drive enable button  in WorkBench v5. Alternatively, the Mint commands RESET or DRIVEENABLE=1 can be used. See the Mint help file for details.

In hardware, a digital input can be used to create the drive enable command. This can be configured in WorkBench v5 using the Digital inputs tab of the Digital I/O tool. Alternatively, the Mint keyword RESETINPUT can be used to select the required digital input. See the Mint help file for details.

Another method is to use the Mint keyword DRIVEENABLEMODE. This allows the combination of DIP switch 8 and the Enable input to create the drive enable command. Both inputs must become active. Provided one input is already on, as soon as the other input changes from off to on (active), the drive will be enabled. See the Mint help file for details.

3.9 DIP switches - SW1

Various functions of the FlexDrive^{II} can be controlled by the front panel SW1 DIP switches.



Location	Switch block SW1	
Switch	Function	
1	8	Node number selection (serial and fieldbus networks) <i>Bit pattern values shown in italics</i>
2	4	
3	2	
4	1	
5	Hold	
6	RS485 terminator	
7	Offset tuning	
8	Enable	
9	<i>(Reserved)</i>	
10	RS232/RS485 select	
Description	10-way DIP switch module for major functions	

3.9.1 Switches 1-4

Switches 1-4 set the network node number (address) after the next power off/on cycle. The switches can be used to select any node number from 1 to 14, as shown in Figure 18.

Switch 1	Switch 2	Switch 3	Switch 4	Node number (address)
Off	Off	Off	Off	Set by Mint NODE keyword
Off	Off	Off	On	1
Off	Off	On	Off	2
Off	Off	On	On	3
Off	On	Off	Off	4
Off	On	Off	On	5
Off	On	On	Off	6
Off	On	On	On	7
On	Off	Off	Off	8
On	Off	Off	On	9
On	Off	On	Off	10
On	Off	On	On	11
On	On	Off	Off	12
On	On	Off	On	13
On	On	On	Off	14
On	On	On	On	Do not use! See section 3.9.7

Figure 18 - Node number (address) switch settings

If switches 1-4 are all in the Off position, the Mint NODE keyword can be used to set the node number. WorkBench v5 (see section 5.2) reads the FlexDrive^{II} node number (during the scan process) and then uses it to direct commands to the FlexDrive^{II}.

Avoid accidentally setting switches 1-4 to the On position at the same time. In combination with DIP switch 8, this will reset the FlexDrive^{II} to its factory defaults. See section 3.9.7.

3.9.2 Switch 5 - Hold

Switch 5 stops the motor. In the Off position, normal operation is allowed. When switched to the On position, the motor decelerates to rest and maintains position. The switch position is sampled every 100ms.

3.9.3 Switch 6 - RS485 terminator

Switch 6 is used to connect a termination resistor to the RS485 network. In the Off position, the RS485 network is unterminated at the FlexDrive^{II}. In the On position, an internal 120Ω termination resistor is connected between the RX+ and RX- signals - see section 4.4.5. Switch 6 should remain in the Off position when using RS232.

3.9.4 Switch 7 - Offset tuning

Switch 7 is used to start offset tuning on analog (command) input AIN0. The purpose of offset tuning is to remove DC offset voltages on analog input 0 (the command reference input) to achieve a stationary motor shaft with 0VDC at the input. Confirm that the device supplying the AIN0 command input is set to its intended zero output setting (nominally 0VDC) before starting offset tuning. When switch 7 is in the On position, offset tuning will start the next time Enable (switch 8) is changed from On to Off.

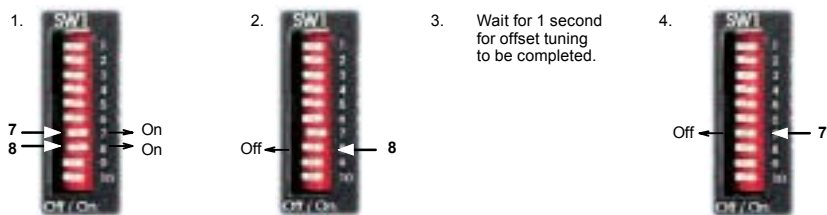

Figure 19 - Offset tuning using switch 7 and 8

Leave switch 7 Off in normal use. After offset tuning, remember to set switch 8 to the On position to allow the drive to be enabled. The switch positions are sampled every 100ms. The Mint keyword ADCOFFSETTRIM can be used to perform the same action.

3.9.5 Switch 8 - Enable

Switch 8 must be set to On to allow the drive to be enabled. The switch position is sampled every 100ms. However, two other actions are necessary to enable the FlexDrive^{II}:

- The enable input (see section 3.8) must be active.
- The drive must also be enabled by using a drive enable command (see section 3.8.3).

3.9.6 Switches 9 and 10 - RS232/RS485 select

Switch 9 is reserved for Baldor keypad selection.

Switch 10 selects RS232 communications (Off) or RS485/RS422 (On) the next time the FlexDrive^{II} is power-cycled.

3.9.7 Factory settings

If switches 1-4 are all in the On position and switch 8 is set to Off, the FlexDrive^{II} will be reset to its preset factory settings at power on (or whenever the processor is reset by WorkBench v5).



CAUTION: Use this function carefully - it will erase your drive setup information.

When using the SW1 DIP switches to reset the FlexDrive^{II} to its factory defaults, all parameters including the node number and serial communications baud rate will be reset. In WorkBench v5, this means it will be necessary to rescan for the FlexDrive^{II} (by starting a new project) to enable communication. It will also be necessary to re-tune your motor and drive.

1. Remove power.

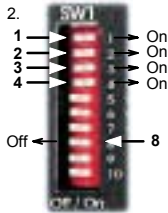

3. Reapply power.

4. FlexDrive^{II} will be reset to its preset factory settings.

Figure 20 - Resetting the FlexDrive^{II} to its factory default settings

The Mint keyword FACTORYDEFAULTS can also be used to reset the FlexDrive^{II} to its factory defaults. However, it will not reset the node number or serial communications baud rate. See the Mint help file for details.

3.9.8 Preventing a program running at startup

Flex+Drive^{II} only:

If switches 5 and 9 are set to On and switch 8 is set to Off, any program already in the Flex+Drive^{II} that contains an Auto command will be prevented from running automatically at startup.

1. Remove power.

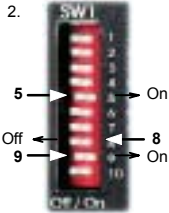

3. Reapply power. Mint program with Auto command will not run.

Figure 21 - Preventing the Auto command from running a stored Mint program

This completes the basic installation.

You should read the following sections in sequence before attempting to start the FlexDrive^{II}.

4.1 Introduction

This section describes the various digital and analog input and output capabilities of the FlexDrive^{II}, with descriptions of each of the connectors on the front panel.

The following conventions will be used to refer to the inputs and outputs:

I/O Input / Output
DIN Digital Input
DOUT Digital Output
AIN Analog Input
AOUT Analog Output
CH Encoder channel

4.2 Analog I/O

The FlexDrive^{II} provides as standard:

- 1 analog input on the connector block X3 (command input)

The analog input is not optically isolated from internal power rails, so care must be taken to avoid earth/ground loops and similar associated problems. The input buffers provide low pass filtering of the applied voltage. To minimize the effects of noise, the analog input signal should be connected to the system using individual shielded / screened cable (a twisted pair cable in the case of differential operation) with an overall shield. The overall shield should then be connected to the chassis at one end only. No other connection should be made to the shield.

If the input is unused, then it is advisable to connect it to the AGND pin. Do not leave the input unconnected (floating).

4.2.1 Analog input - X3 (command)



Location	Connector X3, pins 1-3 (Mating connector: Phoenix MINI-COMBICON MC 1.5/20-ST-3,5)
Name	AIN0
Mint keyword	ADC. 0
Description	Single ended or differential input. Common mode voltage range: $\pm 10\text{VDC}$. Resolution: 14-bit with sign (accuracy $\pm 4.9\text{mV}$) Common mode rejection: 40dB Input impedance: $>5\text{k}\Omega$ Sampling interval: 500 μs - Software (Mint programs) 125 μs - High speed command reference signal

Analog input X3 can be connected as either a differential or a single ended input as shown in Figure 22.

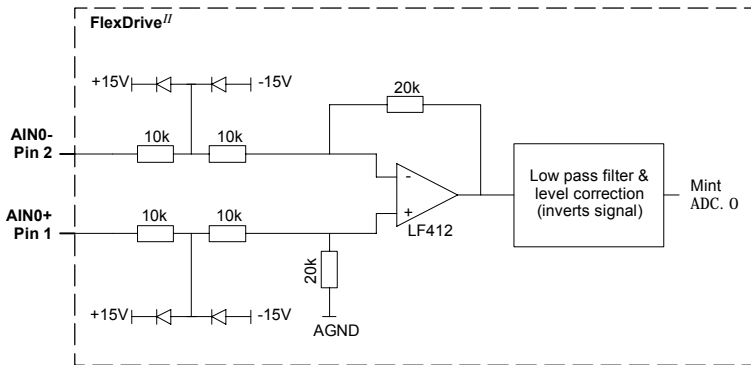

Figure 22 - AIN0 analog input circuit

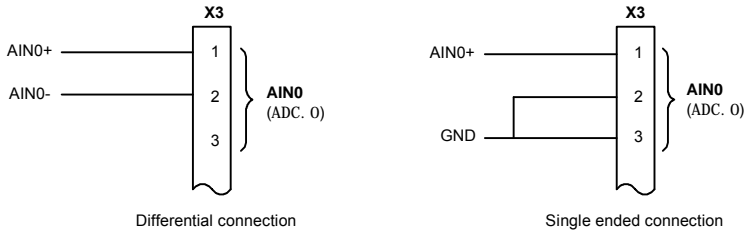

Figure 23 - AIN0 analog input wiring

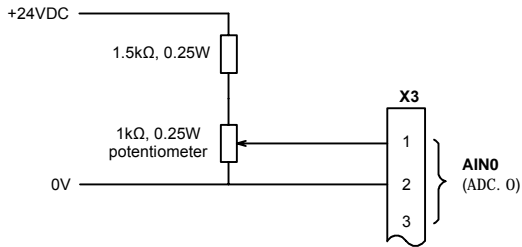

Figure 24 - Typical input circuit to provide 0-10V (approx.) input from a 24V source

4.2.2 Relay output - X3



Location	Connector X3, pins 4 (+) & 5 (-)
Name	General purpose relay
Mint keyword	RELAY
Description	Relay switch contacts controlled by Mint, rated at 1A, 30VDC. Normally closed. Update interval: Immediate

The factory preset assignment for the relay is as the global error output signal (see the Mint keyword GLOBALERROROUTPUT). When an error occurs the relay is de-energized and the normally closed relay contacts are opened. When the error is cleared, the relay is re-energized and the contacts are closed. The relay can be also be controlled directly by the Mint keyword RELAY. When the relay is de-energized (RELAY=_of f) the contacts open.

An axis can use the relay as its drive enable output signal. This can be configured in WorkBench v5 or by using the Mint keyword DRI VEENABLEOUTPUT. This prevents access by RELAY, but means that the relay can be used to monitor the state of the DRI VEENABLE keyword. See the Mint help file for details.

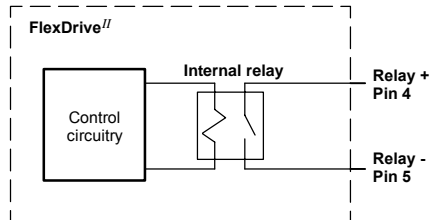

Figure 25 - Relay contact outputs

4.3 Digital I/O

The FlexDrive^{II} provides as standard: *

- 8 general-purpose inputs on connector block X3
- 3 general-purpose outputs on connector block X3

A digital input can be used to support many typical input functions:

- Error input
- Reset input
- Stop input
- Forward limit
- Reverse limit
- Interrupts (controlled from Mint)
- Regeneration resistor (Dynamic Brake) overtemperature input
- PLC Task input conditions
- General purpose use.

Flex+Drive^{II} only:

- Home input
- Index selection and triggering for preset move types
- DIN4 and DIN5 are fitted with Schmitt trigger devices and can be configured using Mint for position capture of the axis or the master/auxiliary encoder positions. See section 4.3.4.
- The main axis' fast input (assigned using the Mint keyword FASTSELECT) can also be used as a trigger for point to point move types. See the Mint help file for details.

* Additional I/O is available on connector X12 if the option B is fitted. See MN1908 *CAN & Auxiliary I/O option for Flex+Drive^{II} and MintDrive^{II}*.

4.3.1 Digital inputs - X3

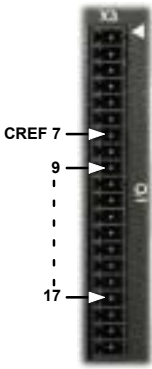

Location	Connector X3	
Pin	Name	Mint keyword
9	Drive Enable	-
10	DIN0	INX. 0
11	DIN1	INX. 1
12	DIN2	INX. 2
13	DIN3	INX. 3
14	DIN4	INX. 4
15	DIN5	INX. 5
16	DIN6	INX. 6
17	DIN7	INX. 7
Description	Eight general-purpose optically isolated AC digital inputs. One committed drive enable input (Drive Enable). Sampling interval: 2ms	

The digital inputs DIN0 - DIN7 can be read individually using the associated Mint keyword INX (for example INX. 7) and can be configured for many user definable functions. Each input circuit contains an opto-isolator as shown in Figure 26. Inputs DIN4 and DIN5 can also be used as fast inputs - see section 4.3.4. The state of each digital input is displayed in the WorkBench v5 Spy window.

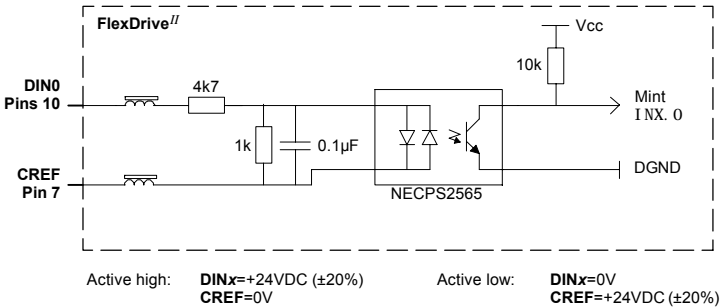

Figure 26 - X3 digital input circuit - DIN0 shown

4.3.2 CREF and digital inputs

Pin 7 (CREF) controls the sense of all the digital inputs (X3 pins 9 to 17) and should be permanently wired, dependent on the user requirements:

Active high: connect 0V to pin 7.

The digital inputs will be active when a voltage of +24VDC (greater than 12VDC) is applied to them and will sink a current of approximately 5mA each.

Active low: connect +24VDC to pin7.

The digital inputs will be active when grounded (less than 2V) and will source a current of approximately 5mA each.

The +24VDC supply is from a customer supplied 24VDC supply that should have a continuous current capability of 1.75A.

The sense of the inputs can be configured in WorkBench v5 or controlled individually in Mint using the keyword `INPUTACTI VELEVEL`.

See section 3.8 for more information about Drive Enable.

4.3.3 Special functions on DIN4 and DIN5 - pulse and direction inputs

DIN4 and DIN5 can be configured using the `MASTERSOURCE` keyword to behave as pulse and direction inputs:

- DIN4 is used as the pulse input. The pulse frequency controls the speed of the motor.
- DIN5 is used as the direction input. The state of the direction input controls the direction of motion. A positive voltage will result in forward motion. If DIN5 is grounded, movement will be in the opposite direction.

Note: If DIN4 and DIN5 have been configured as pulse and direction inputs, the alternative pulse and direction inputs, available on connector X9, cannot be used. See the Mint keyword `MASTERSOURCE`.

4.3.4 Special functions on DIN4 and DIN5 - fast inputs

Flex+Drive^{II} only:

DIN4 and DIN5 can be configured using the FASTSELECT keyword to perform special functions:

- Fast interrupt hardware position capture input. The position of the axis is captured in real time and can be read using the Mint keyword FASTPOS.
- Master or auxiliary encoder input capture, read using the Mint keyword FASTAUXENCODER (DIN5 only).

The maximum latency to read the fast position is approximately 1 μ s. The fast interrupt will be latched on a pulse width of about 30 μ s, although a width of 100 μ s is recommended to ensure capture. To prevent subsequent inputs causing the captured value to be overwritten, the interrupt is latched in software. It is necessary to clear the latch before subsequent interrupts can be detected. See the Mint help file. Both inputs are fitted with Schmitt trigger devices.

Note: The fast inputs are particularly sensitive to noise, so inputs must use shielded twisted pair cable. The inputs are not opto-isolated.

Do not connect mechanical switches, relay contacts or other sources liable to signal 'bounce' directly to the fast inputs. This could cause unwanted multiple triggering.

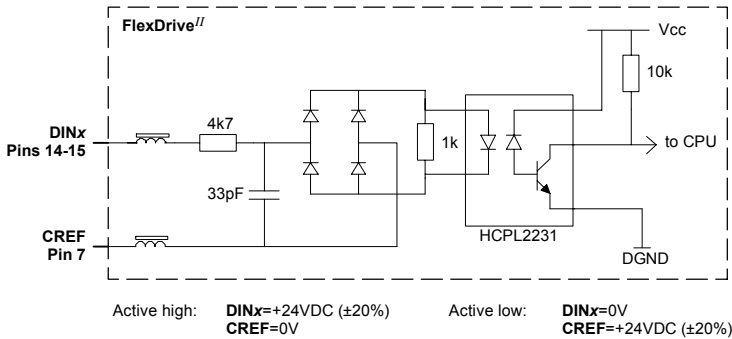
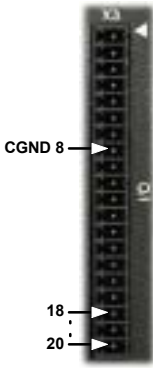

Figure 27 - X3 pulse and direction / fast digital input circuit

4.3.5 Digital outputs - X3



Location	Connector X3	
Pin	Name	Mint keyword
18	DOUT0	OUTX. 0
19	DOUT1	OUTX. 1
20	DOUT2	OUTX. 2
Description	Three general-purpose optically isolated digital outputs. Output current: 50mA maximum each output Update interval: Immediate - Software (Mint programs) 2ms - DRI VEENABLEOUTPUT, DRI VEOKOUTPUT and GLOBALERROROUTPUT functions Programmable - PLC Task functions	

Each optically isolated PNP output is designed to source current from the USR V+ supply as shown in Figure 28. The maximum saturated voltage across any of the outputs when active is 1.0VDC, so they can be used as TTL compatible outputs. If the outputs are used to directly drive a relay, a suitably rated flyback diode must be fitted across the relay coil, observing the correct polarity. This is to protect the output from the back-EMF generated by the relay coil when it is de-energized. The outputs can be written to directly using the Mint keyword OUTX (for example OUTX. 2=1). The sense of the outputs can be configured in WorkBench v5, and their states are displayed in the Spy window.

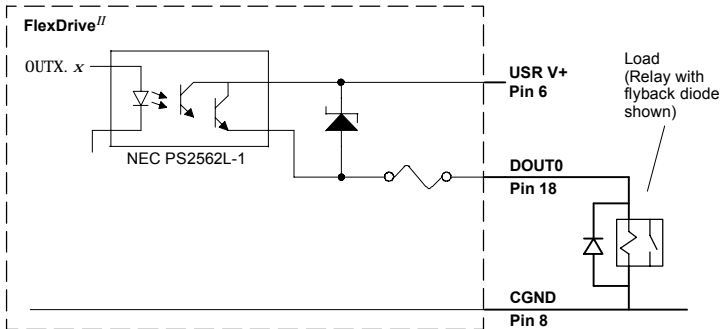

Figure 28 - X3 digital output circuit - DOUT0 shown

4.4 Other I/O

4.4.1 Encoder output - X7



Location	Connector X7
Pin	Name
1	CHA+
2	CHB+
3	CHZ+
4	(NC)
5	DGND
6	CHA-
7	CHB-
8	CHZ-
9	(NC)
Description	Encoder output on a 9-pin female D-type connector

This output can be used for position feedback to a host positioner, or in master/slave situations where the axis movement can be transmitted to another controller or FlexDrive^{II}. It is recommended that this output only drives one output circuit load. The encoder outputs are differential and conform to the RS422 electrical specification. Shielded twisted pair cable is recommended.

If the resolver feedback option is fitted, a simulated encoder output is produced at X7. If the resolver input has been configured to simulate an encoder input of 1024 pulses per revolution (ppr), the output at X7 can be set to either 512 or 1024 ppr. If the resolver input has been configured to simulate an encoder input of 4096 ppr, output modes of 512, 1024, 2048 and 4096 ppr are possible. Note that these values represent actual encoder lines, not quadrature counts. See the keyword ENCODERLI NESOUT in the Mint help file.

If the basic encoder feedback option is fitted, X7 duplicates the encoder signals entering X8.

If the EnDat (absolute encoder) feedback option is fitted, a simulated encoder output is produced at X7. The output ppr is equal to the number of Sin/Cos cycles of the absolute encoder. For example, if a 2048 cycle absolute encoder is connected, the output at X7 will be equivalent to a 2048 ppr encoder. Note that this value represents actual encoder lines, not quadrature counts.

The encoder output supports an index or marker pulse



CAUTION: Using connectors X7 and X8, multiple FlexDrive^{II} units can be 'daisy-chained' together. However, if another Mint based controller such as a NextMoveBX is to be connected, a special cable must be built, as shown in Figure 29:

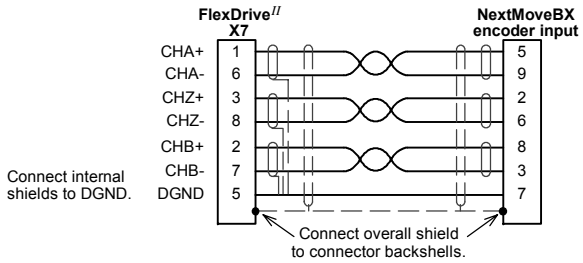
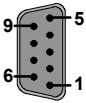

Figure 29 - FlexDrive^{II} encoder output to Mint controller encoder input

4.4.2 Master (auxiliary) encoder input - X9



Location	Connector X9	
Pin	Encoder name	Pulse & direction name
1	CHA+	Pulse+
2	CHB+	Direction+
3	CHZ+	-
4	(NC)	-
5	DGND	-
6	CHA-	Pulse GND
7	CHB-	Direction GND
8	CHZ-	-
9	+5V	-
Description	Optically isolated encoder or pulse and direction input on a 9-pin female D-type connector. Sampling interval: 1 or 2ms	

The FlexDrive^{II} provides an auxiliary (master or handwheel) encoder input that allows it to follow a master encoder or pulse and direction inputs. An interface for a three-channel, incremental encoder (CHA, CHB, CHZ) is provided. The input receiver circuit allows only encoders with differential line drivers (RS422) to be used. The interface also provides an isolated 5V supply for the encoder electronics, capable of driving up to 100mA.



CAUTION: The master encoder input does not use the same pin configuration as some Baldor controllers such as NextMoveBX

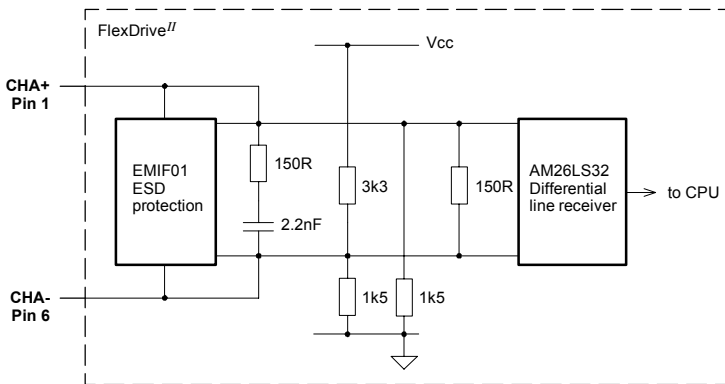

Figure 30 - Master encoder channel input circuit - Channel A shown

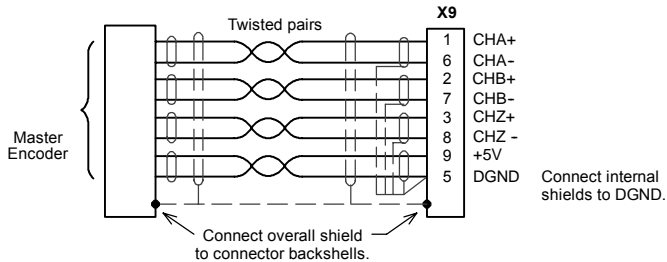

Figure 31 - Differential encoder connections

4.4.2.1 Pulse and Direction following

The master encoder pulse and direction inputs accept 5V differential line driver (RS422) signals from an external source. The pulse frequency controls the speed, and the state of the direction signal controls the direction of motion. A positive direction voltage (greater than 200mV) will result in motion in one direction. A negative direction voltage (less than -200mV) will result in movement in the opposite direction.

The Mint keyword `AUXENCODERMODE` (bit 2) is used to configure X9 for pulse and direction operation. If necessary, the sense of the direction input can be reversed in software using the Mint keyword `AUXENCODERMODE` (bit 0). See the Mint help file for details.

Note: If X9 has been configured for pulse and direction input, the alternative pulse and direction inputs, available on connector X3, cannot be used. See the Mint keyword `MASTERSOURCE`.

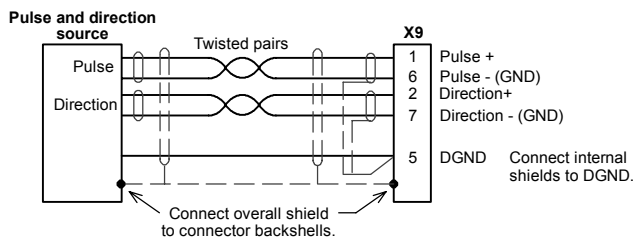
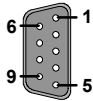

Figure 32 - Pulse and direction connections

4.4.3 Serial port - X6



Location	Connector X6	
Pin	RS232 name	RS485 / RS422 name
1	(NC)	(NC)
2	RXD	RX- (input)
3	TXD	TX- (output)
4	(NC)	(NC)
5	0V GND	0V DGND
6	(NC)	(NC)
7	RTS	TX+ (output)
8	CTS	RX+ (input)
9	<i>(Do not connect! See caution below)</i>	
Description	RS232 or RS485 / RS422 connections on a single 9-pin female D-type connector	

Connector X6 is a 9-pin male D-type connector. This port is configurable as either RS232 or 4-wire RS422 / RS485, using front panel DIP switch number 10 (see section 3.9.6). The Mint keyword `SERI ALBAUD` is used to configure the port and is explained in the Mint help file. See also sections 4.4.4 and 4.4.5. The port is fully ESD protected to IEC 1000-4-2 (15kV).

When using RS485 / RS422 mode, front panel DIP switch number 6 may be used to connect an internal 120Ω termination resistor between the RX+ and RX- signals. Switch 6 should remain in the Off position when using RS232.



CAUTION: Pin 9 is used to carry +8V for powering certain Baldor keypad peripherals. Ensure that pin 9 is not connected to earth/ground or to equipment that could be damaged by the +8V supply.

4.4.4 Using RS232 cable



CAUTION: The serial connector on the FlexDrive^{II} (X6) can be configured as either RS232 or RS485 / RS422. Pin 9 is used to carry +8V for powering certain Baldor keypad peripherals. Ensure that pin 9 is not connected to earth/ground or to equipment that could be damaged by the +8V supply. A suitable cable is available from Baldor, catalog number CBL001-501.

Front panel DIP switch 10 must be in the Off position to select RS232 operation.
The FlexDrive^{II} has a full-duplex RS232 serial port with the following preset configuration:

- 57.6Kbaud
- 1 start bit
- 8 data bits
- 1 stop bit
- No parity
- Hardware handshaking lines (RS232) RTS and CTS must be connected.

This configuration can be changed if required. The RS232 connections are brought out onto a 9-pin male D-type connector. The RS232 port is configured as a DTE (Data Terminal Equipment) unit. Both the output and input circuitry are single ended and operate between $\pm 12V$. The port is capable of operation at up to 57.6Kbaud.

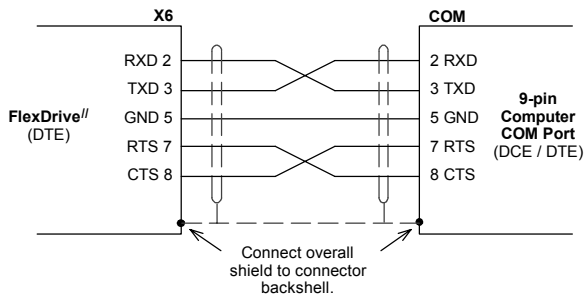

Figure 33 - RS232 serial port connections

The maximum recommended cable length is 3m (10ft) at 57.6Kbaud (the factory preset rate). When using lower Baud rates, longer cable lengths may be used up to maximum of 15m (49ft) at 9600 Baud.

4.4.5 Multidrop using RS485 / RS422 cable

Multidrop systems allow one device to act as a 'network master', controlling and interacting with the other (slave) devices on the network. The network master can be a controller such as a FlexDrive^{II}, a host application such as WorkBench v5 (or other custom application), or a programmable logic controller (PLC). RS422 may be used for multi-drop applications as shown in Figure 34. Four-wire RS485 may be used for single point-to-point applications involving only one Baldor controller. If firmware is updated over RS485/RS422, it can only be downloaded to the drive that was chosen in the Select Controller dialog in WorkBench v5.

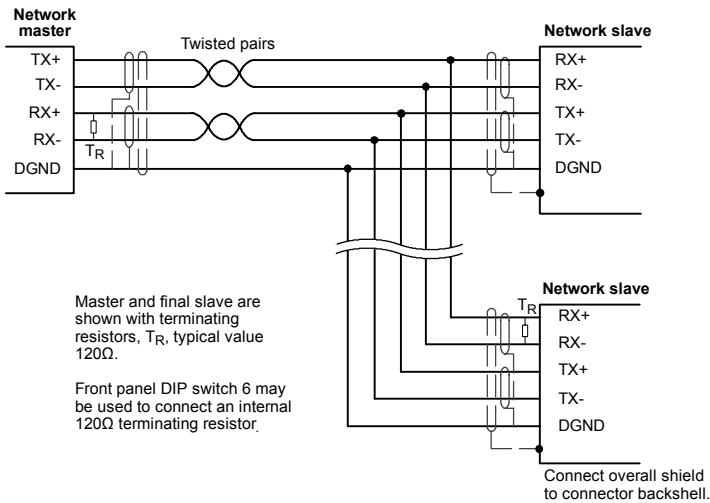
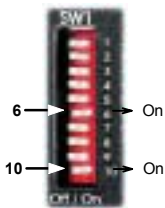

Figure 34 - 4-wire RS422 multi-drop connections



Any FlexDrive^{II} on the network must have its SW1 DIP switch 10 (located on the front panel) set to the On position (see also section 3.9.6). This will set the serial port to RS422/RS485 mode after the next power off/on cycle. When SW1 DIP switch 6 is set to the On position, a 120Ω termination resistor is connected between the RX+ and RX- signals.

Each TX/RX network requires a termination resistor at the final RX connection, but intermediate devices must not be fitted with termination resistors. An exception is where repeaters are being used which may correctly contain termination resistors. Termination resistors are used to match the impedance of the load to the impedance of the transmission line (cable) being used. Unmatched impedance causes the transmitted signal to not be fully absorbed by the load. This causes a portion of the signal to be reflected back into the transmission line as noise. If the source impedance, transmission line impedance, and load impedance are all equal, the reflections (noise) are eliminated. Termination resistors increase the load current and sometimes change the bias requirements and increase the complexity of the system.

4.4.6 Connecting Baldor HMI Operator Panels

Baldor HMI Operator Panels use a 15-pin male D-type connector (marked PLC PORT), but the FlexDrive^{II} connector X6 is a 9-pin male D-type connector. If you do not require hardware handshaking then use the connections shown in Figure 35:

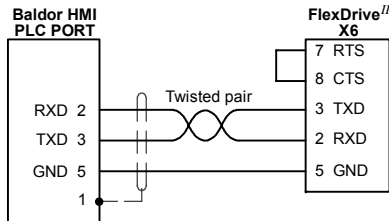

Figure 35 - Cable wiring if hardware handshaking is *not* required

If hardware handshaking is required then use the connections shown in Figure 36:

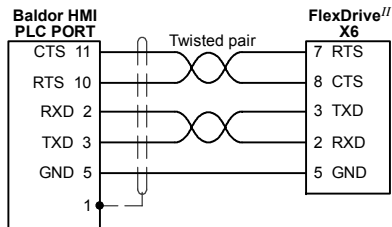
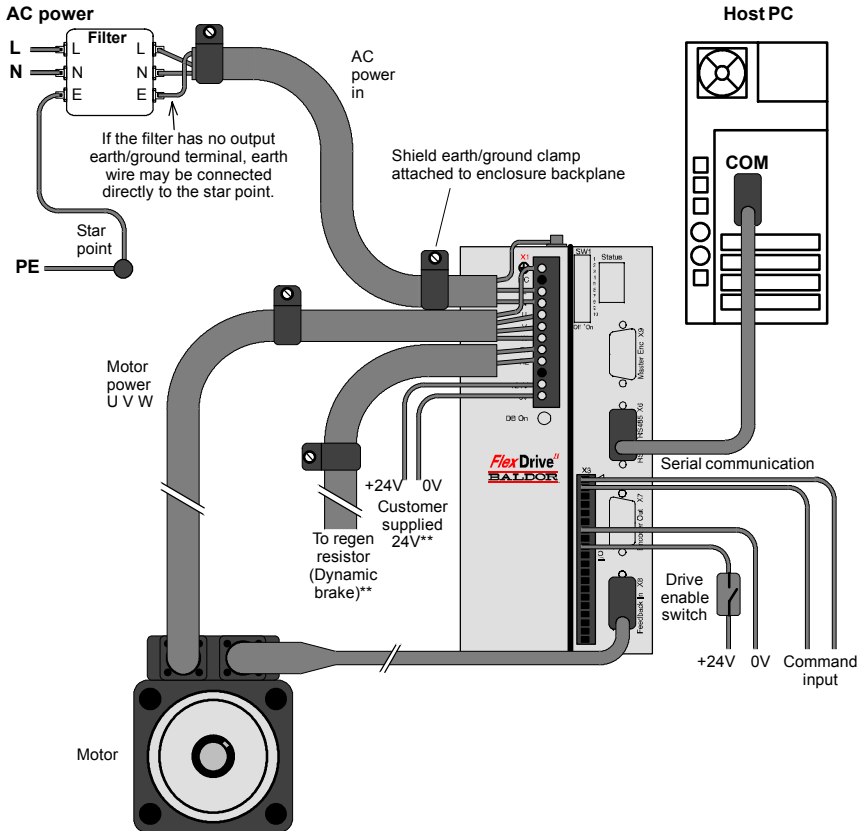

Figure 36 - Cable wiring if hardware handshaking *is* required

4.5 Connection summary - minimum system wiring

As a guide, Figure 37 shows an example of the typical minimum wiring required to allow the FlexDrive^{II} to control a motor.



** Model shown: FDH2A07TR-RN23:

This model requires an external regeneration resistor and customer supplied 24V supply - see sections 3.6 and 3.4.7. Some models contain an internal 24V supply and/or an internal regeneration resistor.

Command input may be differential (shown) or single ended. See section 4.2.1.
Motor represents a typical Baldor BSM motor. Linear motors may also be controlled by FlexDrive^{II}.
Shield earth/ground clamps are not supplied.

Figure 37 - Example minimum system wiring

4.6 Option connectors

If there are additional connectors on the front panel of your FlexDrive^{II} that have not been described in previous sections, these are part of a factory fitted option. You will need to refer to the extra manual supplied with your FlexDrive^{II} for details of the option's connectors.

This completes the input/output wiring.

**You should read the following sections in sequence
before attempting to start the FlexDrive^{II}.**

5.1 Introduction

Before powering the FlexDrive^{II} you will need to connect it to the PC using a serial cable and install the supplied PC software *WorkBench v5*. This software includes a number of tools to allow you to configure and tune the FlexDrive^{II}. If you do not have experience of software installation or Windows applications you may need further assistance for this stage of the installation.

5.1.1 Connecting the FlexDrive^{II} to the PC

Connect the serial cable between a PC serial port (often labeled as "COM") to the FlexDrive^{II} connector X6 (RS232/RS485). WorkBench v5 can scan all the COM ports, so you can use any port.



CAUTION: The serial connector on the FlexDrive^{II} (X6) can be configured as either RS232 or RS485 / RS422. If this is the first time you are installing a FlexDrive^{II} then it is strongly recommended that you use RS232 to get started (the preset factory setting) and use RS485 later. Pin 9 is used to carry +8V for powering a Baldor keypad peripheral. Ensure that pin 9 is not connected to earth/ground or to equipment that could be damaged by the +8V supply. A suitable cable is available from Baldor, catalog number CBL001-501.

5.1.2 Installing the software

The CDROM containing the software can be found separately within the packaging.

1. Insert the CDROM into the drive.
2. After a few seconds the setup wizard should start automatically. If the setup wizard does not appear, select Run... from the Windows Start menu and type

d:\start

where **d** represents the drive letter of the CDROM device (use the correct letter for your installation).

Follow the on-screen instructions to install WorkBench v5. The setup wizard will copy the files to appropriate folders on the hard drive. The default folder is C:\Program Files\Baldor\MintMT, although this can be changed during setup.

5.1.3 Starting the FlexDrive^{II}

If you have followed the instructions in the previous sections, you should now have connected all the power sources, your choice of inputs and outputs and the serial cable linking the PC with the FlexDrive^{II}.

5.1.4 Preliminary checks

Before you apply power for the first time, it is very important to verify the following:

- Disconnect the load from the motor until instructed to apply a load. If this cannot be done, disconnect the motor wires at connector X1/X1A.
- Verify that the front panel DIP switches 1-9 are in the Off position. It is recommended that you use RS232 communications to begin with, in which case DIP switch 10 must also be in the Off position. However, if you are using RS485/RS422 communication then DIP switch 10 must be in the On position (also DIP switch 6 if termination is required).
- Verify that the AC line voltage matches the specification of the FlexDrive^{II}.
- Inspect all power connections for accuracy, workmanship and tightness.
- Verify that all wiring conforms to applicable codes.
- Verify that the FlexDrive^{II} and motor are properly earthed/grounded.
- Check all signal wiring for accuracy.

5.1.5 Power on checks

If at any time the Status display shows a flashing symbol or 'E.' this indicates that the drive has detected a fault - see section 6.

1. Turn on the 24VDC supply (only for FlexDrive^{II} with catalog numbers FDHxxxxx-xxx3 / FPHxxxxx-xxx3).
2. Turn on the AC supply.
3. After a brief test sequence, the Status display should show a minus sign (-).

If the display is not lit then re-check the power supply connections.

4. If the motor wires were disconnected in section 5.1.4, turn off the AC supply and reconnect the motor wires. Turn on the AC supply.
5. To allow the Commissioning Wizard to function, SW1 DIP switch 8 will need to be set to the On position to allow the FlexDrive^{II} to be enabled. If you do not wish to enable the FlexDrive^{II} yet, the Commissioning Wizard will inform you when this step is necessary.
6. To allow the Commissioning Wizard to function, the +24VDC drive enable signal will need to be present on connector X3 (between pins 7 and 9) to allow the FlexDrive^{II} to be enabled. If you do not wish to enable the FlexDrive^{II} yet, the Commissioning Wizard will inform you when this step is necessary.

The FlexDrive^{II} is now ready to be commissioned using WorkBench v5.

5.1.6 Offset tuning

If the FlexDrive^{II} will be using analog input 0 (AIN0) as a command reference input (or for any other purpose) you may wish to perform offset tuning before continuing. The purpose of offset tuning is to remove DC offset voltages on the command reference input to achieve a stationary motor shaft with 0VDC at the input. Offset tuning is controlled by DIP switches 7 and 8.

Before starting, confirm that the device supplying the AIN0 command input is set to its intended zero output setting (nominally 0VDC).

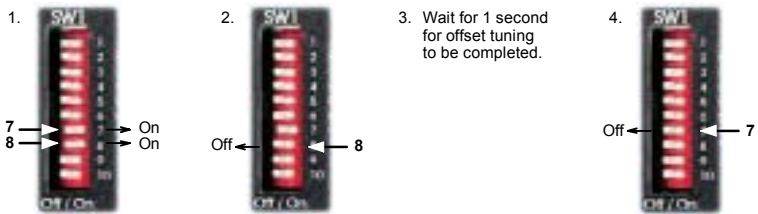



Figure 38 - Offset tuning using switch 7 and 8

After offset tuning, remember to set switch 8 to the On position to allow the drive to be enabled.

5.2 WorkBench v5

WorkBench v5 is a fully featured application for programming (Flex+Drive^{II} only) and controlling the FlexDrive^{II}. The main WorkBench v5 window contains a menu system, the Toolbox and other toolbars. Many functions can be accessed from the menu or by clicking a button - use whichever you prefer. Most buttons include a 'tool-tip'; hold the mouse pointer over the button (don't click) and its description will appear.

5.2.1 Help file

WorkBench v5 includes a comprehensive help file that contains information about every Mint keyword, how to use WorkBench v5 and background information on motion control topics. The help file can be displayed at any time by pressing F1. On the left of the help window, the Contents tab shows the tree structure of the help file. Each book  contains a number of topics . The Index tab provides an alphabetic list of all topics in the file, and allows you to search for them by name. The Search tab allows you to search for words or phrases appearing anywhere in the help file. Many words and phrases are underlined and highlighted with a color (normally blue) to show that they are links. Just click on the link to go to an associated keyword. Most keyword topics begin with a list of relevant See Also links.

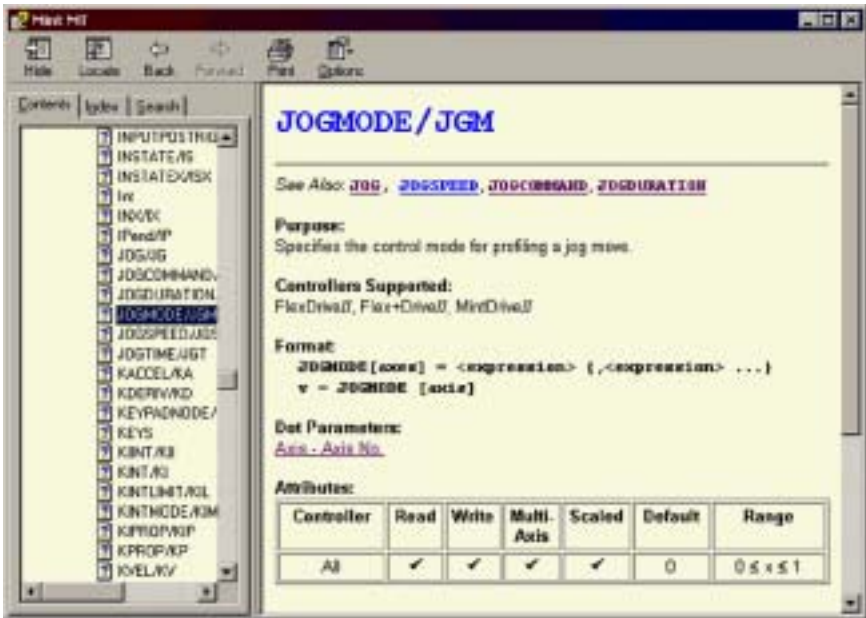



Figure 39 - The WorkBench v5 help file

For help on using WorkBench v5, click the **Contents** tab, then click the small plus sign  beside the **WorkBench v5** book icon. Double click a  topic name to display it.

5.2.2 Starting WorkBench v5

1. On the Windows **Start** menu, select Programs, WorkBench v5, WorkBench.

WorkBench v5 will start, and the Tip of the Day dialog will be displayed.

You can prevent the Tip of the Day dialog appearing next time by removing the check mark next to Show tips at startup.

Click **Close** to continue.



2. In the opening dialog box, click **Start New Project...**



3. In the Select Controller dialog, go to the drop down box near the top and select the PC serial port to which the drive is connected.

(If you are unsure which PC serial port is connected to the drive, select **Scan all serial ports**).

Click **Scan** to search for the FlexDrive^{II}.

When the search is complete, click on FlexDrive^{II} in the list to select it, and click the **Select** button.



This check box is already selected for you. When you click **Select**, it means that the Commissioning Wizard will start automatically.

Note: If the FlexDrive^{II} is not listed, check the serial lead between the FlexDrive^{II} and the PC and that the FlexDrive^{II} is powered correctly. Click **Scan** to re-scan the ports.

5.2.3 Commissioning Wizard

Each type of motor and drive combination has slightly different performance characteristics. Before the FlexDrive^{II} can be used to control the motor accurately, the FlexDrive^{II} must be “tuned”. This is the process where the FlexDrive^{II} powers the motor in a series of tests. By monitoring the feedback from the motor’s resolver or encoder and performing a number of calculations, the FlexDrive^{II} can make small adjustments to the way it controls the motor. This information is stored in the FlexDrive^{II} EEPROM and can be uploaded to a file if necessary. The Commissioning Wizard provides a simple way to tune the FlexDrive^{II} and create the necessary configuration information for your drive/motor combination, so this is the first tool that should be used.

5.2.4 Using the Commissioning Wizard



CAUTION: The motor will move during commissioning. For safety it is advisable to disconnect any load from the motor during initial commissioning. The motor can be tuned with the load connected after the Commissioning Wizard has finished.

Each screen of the Commissioning Wizard requires you to enter information about the motor or drive. Read each screen carefully and enter the required information.

If you need extra help, click the **Help** button or press F1 to display the help file.

When you have completed a screen, click **Next >** to display the next screen. If you need to change something on a previous screen, click the **< Back** button. The Commissioning Wizard remembers information that you have entered so you will not need to re-enter everything if you go back to previous screens.

5.2.5 Completing the Commissioning Wizard

The final screen (Tuning) has a Finish button that is grayed out until the tuning tests have been completed. When the tuning tests have finished click **Finish** to complete the Commissioning Wizard.

The parameters that have been calculated by the Commissioning Wizard do not need to be downloaded to the FlexDrive^{II}. They are already in the FlexDrive^{II} and will not be lost even when it is powered down.

5.3 Further configuration

WorkBench v5 provides a number of tools, each of which has an icon on the left of the screen. Click once on an icon to select the tool. Three of the main tools used for tuning and configuring the FlexDrive^{II} are described in the following sections.

Every tool is explained fully in the help file. Press F1 to display the help file, then navigate to the WorkBench v5 book. Inside this is the Toolbox book.

5.3.1 Fine-tuning tool

The Commissioning Wizard calculates many parameters that allow the FlexDrive^{II} to provide basic control of the motor. These parameters may need to be fine-tuned to provide the exact response that you require. The Fine-tuning screen allows you to do this.

1. Click the Fine-tuning icon in the Toolbox on the left of the screen.

The Fine-tuning window is displayed at the right of the screen. This already shows some of the parameters that have been calculated by the Commissioning Wizard.



The main area of the WorkBench v5 window displays the capture window. When further tuning tests are performed, this will display a graph representing the response.

2. The Fine-tuning window has three tabs at the bottom - Position, Speed and Current. Click on a tab to select it.

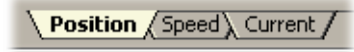

Click the tab for the type of tests you wish to perform.

Note: Some tabs may not be available depending on the configuration mode you selected in the Commissioning Wizard.

5.3.1.1 Fine-tuning - Position tab

The position tab allows you to set position loop gains and perform test moves. The Commissioning Wizard may have already set some of these values, depending on the type of system selected on the mode screen.

Enter new values in the required boxes and then click **Apply** to download the values to the FlexDrive^{II}. To perform tests, go to the Test Parameters area at the bottom of the tab. Enter test values and then click **Go** to perform the test move. If you need help, just press F1 to display the help file.

5.3.1.2 Fine-tuning - Speed tab

The speed tab allows you to set speed loop gains and perform test moves. The Commissioning Wizard may have already set some of these values, depending on the type of system selected on the mode screen.

Enter new values in the required boxes and then click **Apply** to download the values to the FlexDrive^{II}. To perform tests, go to the Test Parameters area at the bottom of the tab. Enter test values and then click **Go** to perform the test move. If you need help, just press F1 to display the help file.

5.3.1.3 Fine-tuning - Current tab

The current tab allows you to set current loop gains and perform test moves. The Commissioning Wizard may have already set some of these values, depending on the type of system selected on the mode screen.

Enter new values in the required boxes and then click **Apply** to download the values to the FlexDrive^{II}.

To perform tests, go to the Test Parameters area at the bottom of the tab. Enter test values and then click **Go** to perform the test move. If you need help, just press F1 to display the help file.

The additional **Measure** and **Feedback alignment** buttons can be used to repeat the same measurement and alignment tests as the Commissioning Wizard.

5.3.2 Parameters tool

The Parameters tool can be used to setup many important parameters, such as a scaling factor for the feedback input, and the action to take when errors occur.

1. Click the Parameters icon in the Toolbox on the left of the screen.

The main area of the WorkBench v5 window displays the Controller Parameters screen.



2. The Controller Parameters screen has a number of tabs listed on the left. Click on a tab to select it.

If you need help with any of the options, just press F1 to display the help file.

Remember to click the tab's **Apply** button to send the changes to the FlexDrive^{II}.

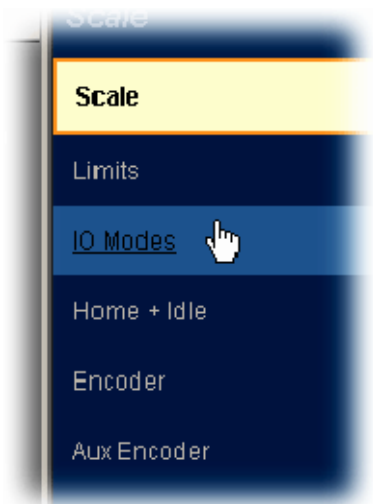

5.3.3 Digital I/O tool

The Digital I/O tool allows you to define how each digital input and output will be triggered and if it is to be assigned to a special function, for example the forward limit or stop input.

1. Click the Digital I/O icon in the Toolbox on the left of the screen.

The main area of the WorkBench v5 window displays the Digital I/O screen. You can use a drag and drop method to assign triggering options to inputs and outputs and assign them to special purpose functions.

If you need help, just press F1 to display the help file. Remember to click the **Apply** button to send the changes to the FlexDrive^{II}.



5.3.4 Other tools and windows

Each tool and window is explained fully in the help file, so is not described here in detail.

- **Edit & Debug Tool**
This tool provides a work area including the Command window and Output window. The Command window can be used to send immediate Mint commands to both the FlexDrive^{II} and Flex+Drive^{II}.
- **Scope Tool**
Displays the capture screen. This screen is also shown when the Fine-tuning tool is selected.
- **Jog Tool**
Allows you to perform jog moves - useful for testing purposes.
- **PLC Task Tool**
Allows you to setup the PLC Task, a special task that can be used to check for a number of pre-defined conditions and then perform actions if they become true.
- **Error Log Tool**
Displays a list showing when errors occurred and when they were cleared.
- **Spy window**
Allows you to monitor all the important parameters for the axis, and shows the state of digital inputs and outputs, limit switches and comms locations.

Flex+Drive^{II} only:

- **Edit & Debug** also provides the environment for programming the Flex+Drive^{II}. Multiple editing windows can be opened for entering program code.
 - **Presets Tool**
Allows you to setup preset moves and the way in which they should be triggered. An interactive table of the moves is used to make changes.
 - **Homing Tool**
Allows you to setup homing moves.
-

Remember, for help on each tool just press F1 to display the help file, then navigate to the WorkBench v5 book. Inside this is the Toolbox book.

6.1 Introduction

This section explains common problems that may be encountered, together with possible solutions.

6.1.1 Problem diagnosis

If you have followed all the instructions in this manual in sequence, you should have few problems installing the FlexDrive^{II}. If you do have a problem, read this section first. In WorkBench v5, use the Error Log tool to view recent errors and then check the help file. If you cannot solve the problem or the problem persists, the SupportMe™ feature can be used.

6.1.2 SupportMe™ feature

The SupportMe™ feature (on the Help menu) can be used to e-mail information to the Baldor representative from whom you purchased the equipment. If required, you can choose to add your program files as attachments. WorkBench v5 will automatically start up your e-mail program and begin a new message, with comprehensive system information and selected attachments already in place. You can add any additional message of your own and then send the e-mail. The PC must have email facilities to use the SupportMe™ feature. If you prefer to contact Baldor technical support by telephone or fax, contact details are provided at the front of this manual. Please have the following information ready:

- The serial number of your FlexDrive^{II}.
- Use the Help, SupportMe menu item in WorkBench v5 to view details about your system.
- The catalog and specification numbers of the motor that you are using.
- Give a clear description of what you are trying to do, for example trying to establish communications with WorkBench v5 or trying to perform fine-tuning.
- Give a clear description of the symptoms that you can observe, for example the Status display, error messages displayed in WorkBench v5, or the current value of any of the Mint error keywords AXI SERROR, AXI SSTATUS, I NI TERROR, MI SCERROR and DRI VEERROR.
- The type of motion generated in the motor shaft.
- Give a list of any parameters that you have setup, for example the motor data you entered/selected in the Commissioning Wizard, the gain settings generated during the tuning process and any gain settings you have entered yourself.

6.1.3 Power-cycling the FlexDrive^{II}

The term "Power-cycle the FlexDrive^{II}" is used in the Troubleshooting sections. On models with a customer supplied 24V supply, remove the 24V supply, wait for the FlexDrive^{II} to power down completely (all Status LED segments will turn off), then re-apply the 24V supply. On models with an internally generated 24V supply, remove the AC power supply, wait for the FlexDrive^{II} to power down completely (all Status LED segments will turn off), then re-apply AC power.

6.2 FlexDrive^{II} indicators

6.2.1 Status display

The Status LED display indicates general FlexDrive^{II} status information. Some characters will flash to indicate an error.



0.	<p>Drive / comms watchdog. Interprocessor communications failure. This is potentially a severe problem if it occurs repeatedly. Communications failure could indicate a process locking out the interprocessor communications. Clear the error; if the problem persists then contact Baldor technical support.</p>
1.	<p>Over volts. The DC Bus voltage has exceeded the powerbase overvolts level (see DRI VEBUSOVERVOLTS). Check the DC Bus level being fed into the system (see Mint keyword DRI VEBUSVOLTS). This should be close to the nominal voltage (see Mint keyword DRI VEBUSNOMI NALVOLTS). Ensure that your input voltage is relevant to the voltage rating of your drive. If the input voltage is correct, then this error may be the result of high deceleration rates. If it is not possible to reduce the harshness of the deceleration rate, then a regeneration resistor should be used. To help you, use WorkBench v5 capture facility to monitor the DC Bus level during moves.</p>
2.	<p>Integrated Power Module (IPM) trip. The unit's powerbase has been overloaded. This should not happen in normal use if limits have been configured correctly. See the Mint keyword CURRENTLIMIT and related commands.</p>
3.	<p>Current trip. Instantaneous over-current trip. One or more of the 3 motor phases has exceeded 300% of Drive Rated Current.</p>
4.	<p>Under volts. The DC Bus voltage has dropped below the powerbase undervolts level (see DRI VEBUSUNDERVOLTS). This error will only be generated if the drive is in the enabled state. As with the overvolts error, check the input voltage being fed into the system. The error could also occur during high acceleration profiles.</p>
5.	<p>Feedback trip. Can be enabled/disabled using FEEDBACKFAULTENABLE. Five consecutive errors (or five errors in any 500 servo tick period) will cause the drive to trip. This error indicates loss of encoder/resolver feedback and may indicate that the feedback cable has become detached or one of the signals has broken. Check the wiring in the Feedback cable; check for noise immunity; check the feedback device fitted to the motor (if possible).</p>
6.	<p>Motor or Drive trip. The motor I²T or the drive I.T current protection algorithms have exceeded their limit and tripped the drive (disabled it). Check DRI VEERROR or the Error Log to determine which error has occurred. The motor and drive current limits are fixed according to the database parameters. The drive can demand peak current for a short duration (see DRI VEPEAKDURATION), thereafter it will trip or Foldback according to the setting of DRI VEOVERLOADMODE. The same is true for the motor (see MOTORPEAKDURATION and MOTOROVERLOADAREA). Use the Foldback option to automatically foldback the current to a level where the drive/motor can recover.</p>

7	(Symbol not flashing) Motor I ² T / It foldback. Motor I ² T or Drive I.T algorithm has resulted in the demand current being folded back to a level where the drive/motor can recover. The motor / drive can run with demand currents greater than their rated value for a period of time; after that time the drive will either trip or automatically foldback the demand current.
7.	Overtemperature. The temperature of the drive or motor has exceeded a trip level (see Mint keyword TEMPERATURELIMITFATAL) or the Motor overtemperature trip input has been activated (see Mint keyword MOTORTEMPERATUREINPUT).
8	Drive enabled. The drive is enabled (except where CONFIG = _cfVirtual , where it is not physically enabled).
9	Torque mode. The drive is in Torque mode. See the Mint keywords TORQUE, TORQUERESOURCE and related commands.
A	Auto tune test driving motor. Autotune is active and driving the motor. The motor may move.
b.	Power base not ready. This error condition applies to 3-phase drives only. These drives have a pre-charge circuit which must activate after power-up before the drive can be enabled. If the drive is enabled prior to this then the error occurs. The error could also indicate the loss of one or more of the input phases.
c	Cam. A Cam profile is being profiled. See the Mint keyword CAM.
E.	General error. See AXI ERROR and DRIVEERROR. The motion toolbar displays the status of AXI ERROR, which is a bit pattern of all latched errors. See also the <i>Error Log</i> topics in the help file.
e.	Error input. The ERRORINPUT has been activated and generated an error.
F	Flying shear. A flying shear is being profiled. See the Mint keyword FLY.
F.	Position or velocity following error. A following error has occurred. See the Mint keyword AXI ERROR and associated keywords. Following errors could be caused by a badly tuned drive/motor. At higher acceleration and deceleration rates, the following error will typically be greater. Ensure that the drive/motor is adequately tuned to cope with these acceleration rates. The following error limit can be adjusted to suite your application (see Mint keywords FOLERRORFATAL and VELFATAL). Following error could also be the cause of encoder/resolver loss (see also Mint keyword FEEDBACKFAULTENABLE).
7	Follow mode. The drive is in Follow mode. See the Mint keyword FOLLOW.
H	Hold. The Hold DIP switch is active (see section 3.9.2) or the PLC Task has requested a Hold state. Motion will be ramped to zero demand and will then hold on position while the switch is active.
h	Homing. The drive is currently homing. See the Mint keyword HOME.
h.	Preset Homing. The drive is currently homing. This motion has been triggered from a Preset move table.

I	Incremental move. An incremental move is being profiled. See the Mint keywords I NCA and I NCR.
J	Jog. The drive is jogging. In the Mint help file, see the topics JOG, JOGCOMMAND and Jog screen.
J.	Preset jog. The drive is jogging. The jog was triggered from a Preset jog table.
O	Overspeed. The measured speed of the motor has exceeded the trip level defined by DRI VESPEEDFATAL. Check that the trip level is set to a suitable value for your application. When accelerating to a demand speed close to the trip level, there will typically be a certain amount of overshoot. Using the Fine-tuning tool, check the amount of overshoot you get with the acceleration and demand speeds being used in your application.
P	Positional Move. The drive is performing a linear move. See the Mint keywords MOVEA and MOVER.
P.	Preset positions. The drive is performing a linear move. This motion has been triggered from a Preset move table.
r.	DB Overload. The regeneration resistor (Dynamic Brake) has been overloaded. See the Mint keyword DBEXTTRI PSWI TCH and associated keywords.
S	Stop. A STOP command has been issued or the stop input is active.
-	Drive disabled. The drive must be enabled before operation can continue. See section 3.8. Click the Drive enable button in WorkBench v5.
-	Crash. The drive enable input or the Enable DIP switch have become inactive whilst the drive was in the enable state (or the drive was enabled whilst they were inactive) - bit 13 in AXI SEERROR will be set. The drive can be programmed to ignore this state using the Mint keyword DRI VEENABLEI NPUTMODE (see the Parameters tool).
=	Suspend. The SUSPEND command has been issued and is active. Motion will be ramped to zero demand whilst active.
S	Speed demand. The drive is under speed control. See the Mint keywords SPEEDREF, SPEEDREFSOURCE and related commands.
f.	Reverse software or hardware limit. A reverse software limit has been activated. See AXI SERROR and/or AXI SSTATUS to determine which applies.
f.	Forward software or hardware limit. A forward software limit has been activated. See AXI SERROR and/or AXI SSTATUS to determine which applies.
=	Firmware being updated (horizontal bars appear sequentially). New firmware is being downloaded to the drive.
I.	Initialization error. An initialization error has occurred at power on. See the <i>Error Log</i> or I NI TERROR topics in the help file. Initialization errors should not normally occur.

User defined symbols can be made to appear using the Mint keywords LED and LEDDI SPLAY.

6.2.2 DB On (Regeneration) LED



The front panel **DB On** LED indicates regeneration activity.

Yellow	Power is being dissipated into the regeneration resistor
Off	No regeneration is occurring.

6.2.3 Communication

Problem	Check
Status display is blank	Check that the customer supplied 24VDC power supply is connected correctly to connector X1 and is switched on. On models with an internally generated 24VDC supply, check that the AC power supply is connected correctly to connector X1 and is switched on.
WorkBench v5 fails to detect the FlexDrive ^{II} - it detects "No controller found. Communication fault on COMx".	Ensure that the FlexDrive ^{II} is powered and the Status display is illuminated (see section 6.2). Check that the serial cable is connected between the PC's COM port and connector X6 on the FlexDrive ^{II} . Check which PC COM port is being used, or use the "Scan all serial ports" option to locate the FlexDrive ^{II} . Check the wiring of the serial cable or try an alternate cable. Check that DIP switch 10 (RS232/RS422) is set correctly (see section 3.9.6). On the PC, try an alternative COM port. Confirm that a mouse driver or other serial device is not conflicting (using the same COM port) as WorkBench v5. Does the FlexDrive ^{II} have firmware in it? If you tried to download new firmware and the download failed, the controller may not have firmware. If this has happened, the Status display will show a minus sign (-) and flash the decimal point repeatedly. Check that the selected Baud rate is supported by the PC and FlexDrive ^{II} . If the "Only scan COMx" option is selected in WorkBench v5, check that the correct COM port is selected. If the "Search up to Nodexx" option is selected in WorkBench v5, check that the FlexDrive ^{II} node number is not higher than this value. Do you have multiple nodes on the bus? If so, they must all be set to the same Baud rate. WorkBench v5 scans through all the node Id's at different Baud rates. When it finds a node, it will only continue to scan for other nodes at the same Baud rate.

6.2.4 Power on

Problem	Check
The Status display is showing a flashing symbol with a static decimal point.	The FlexDrive ^{II} has detected a motion error. Use the Error Log tool to view a list of recent errors, or click the Error button on the motion toolbar to view a description of the error. Alternatively, type any or all of these commands in the Command window: PRINT AXI SERROR PRINT DRI VEERROR PRINT MI SCERROR PRINT I NI TERROR Click the Clear Errors button on the motion toolbar.

6.2.5 Tuning

Problem	Check
Cannot enable the FlexDrive ^{II} because AXI SERROR has bit 13 set	Check the drive enable input on connector X3 pins 7 and 9 is connected and powered correctly. Check that DIP switch 8 (enable) is set to the On position.
When the FlexDrive ^{II} is enabled the motor is unstable	Check that the current loop has been tuned. Check that the current loop was tuned with the correct motor data. If the motor is still unstable try reducing the Speed Proportional gain (KVPROP) and Speed Integral gain (KVI NT) on the Speed tab of the Fine-tuning window.
I get a Following Error (AXI SERROR bit 5 is set) and the drive disables when tuning the Mint gains	Set FOLERRORMODE to zero to ignore the following error while tuning the Mint gains.
I get a Software limit error (AXI SERROR bits 3 or 4 set) and the drive disables when tuning the Mint gains	Set SOFTLI MI TMODE to zero to ignore the software limit error while tuning the Mint gains.
I get a Hardware limit error (AXI SERROR bits 1 or 2 set) and the drive disables when tuning the Mint gains	Set LI MI TMODE to zero to ignore the hardware limit errors while tuning the Mint gains. Alternatively, disable the hardware limit inputs.

6.2.6 Status display shows a digit or 'E.'

If the Status display shows a flashing digit, 'E' or the forward or reverse hardware limit symbol, use the Error Log tool to view a list of recent errors. Alternatively, type PRINT DRI VEERROR, PRINT AXI SERROR and PRINT MI SCERROR as separate commands in the WorkBench v5 Command window. Each of these commands will return an error code, a description of which can be found in the help file.

Press F1 and locate the DRI VEERROR, AXI SERROR and MI SCERROR keywords. The *Error Handling* book contains topics listing the Status display indicators and basic error codes.

Remember that many error codes are the sum of a bit pattern so may not be listed individually. For help on understanding bit pattern values, see the *Bit pattern values* topic in the *Keywords* book.

7.1 Introduction

This section provides technical specifications for the various FlexDrive^{II} models.

7.1.1 AC input power and motor output - single-phase models

115VAC (Catalog number FDH1... / FPH1...)	Unit	2.5A	5A	7.5A
Nominal input voltage	VAC	115		
Minimum input voltage		97		
Maximum input voltage		125		
Nominal DC-Bus voltage	VDC	160		
Minimum DC-Bus voltage		135		
Maximum DC-Bus voltage		176		

230VAC (Catalog number FDH2... / FPH2...)	Unit	2.5A	5A	7.5A
Nominal input voltage	VAC	230		
Minimum input voltage		220		
Maximum input voltage		250		
Nominal DC-Bus voltage	VDC	320		
Minimum DC-Bus voltage		306		
Maximum DC-Bus voltage		350		

<i>All single-phase models (Catalog numbers: FDH1... / FPH1... and FDH2... / FPH2...)</i>	Unit	2.5A	5A	7.5A
Output voltage (line-line) @VDC-Bus=320V	V_{RMS}	0 - 230		
Nominal phase current (±10%)	A_{RMS}	2.5	5.0	7.5
Peak phase current (±10%) 2.5A & 5A: for 2.4s (+0.5s / -0s) 7.5A: for 1.25s (+0.5s / -0s)	A_{RMS}	5	10	15
Nominal output power	kVA	1.01	2.17	2.99
Efficiency	%	>95		
Output frequency	Hz	0 - 500		
Nominal switching frequency	kHz	8.0		

7.1.2 AC input power and motor output - 230V three-phase models

230VAC 50/60Hz <i>(Catalog numbers FDH2A15... and FPH2A15...)</i>	Unit	15A
Nominal input voltage	VAC	230
Minimum input voltage		184
Maximum input voltage		253
Nominal DC-Bus voltage	VDC	320
Minimum DC-Bus voltage		258
Maximum DC-Bus voltage		355 (Programmable using Mint keyword DRI VEBUSOVERVOLTS)
Output voltage (line-line) @VDC-Bus=320V	V_{RMS}	0 - 250
Nominal phase current (±10%)	A_{RMS}	15
Peak phase current (±10%) for 1.25s (+0.5s / -0s)	A_{RMS}	30
Nominal output power	kVA	5.2
Efficiency	%	>95
Output frequency	Hz	0 - 500
Nominal switching frequency	kHz	8.0

7.1.3 AC input power and motor output - 230-460V three-phase models

230-460VAC 50/60Hz <i>(Catalog number FDH4... / FPH4...)</i>	Unit	2.5A	5A	7.5A	15A	20A	27.5A
Nominal input voltage	VAC	230-460					
Minimum input voltage		180					
Maximum input voltage		528					
Nominal DC-Bus voltage	VDC	325 (230VAC input) / 650 (460VAC input)					
Minimum DC-Bus voltage		254					
Maximum DC-Bus voltage		746 (Programmable using Mint keyword DRI VEBUSOVERVOLTS)					
Output voltage (line-line) @VDC-Bus=500V	V_{RMS}	0 - 353					
Nominal phase current (±10%)	A_{RMS}	2.5	5.0	7.5	15	20	27.5
Peak phase current (±10%) for 1.25s (+0.5s / -0s)	A_{RMS}	5	10	15	30	40	55
Nominal output power	kVA	1.9	3.8	5.7	11.4	15.2	20.9
Efficiency	%	>95					
Output frequency	Hz	0 - 500					
Nominal switching frequency	kHz	8.0					

7.1.4 Customer supplied 24VDC supply input

24VDC <i>(Catalog numbers FDHxxxxx-xxx3 and FPHxxxxx-xxx3)</i>	Unit	2.5A	5A	7.5A	15A	20A	27.5A
Nominal input voltage	VDC	24					
Minimum input voltage		20.4					
Maximum input voltage		28.8					
Maximum ripple	%	±10					
Maximum continuous current @24VDC	A	1.75					
Power on surge current @24VDC, 100ms	A	4					

7.1.5 Regeneration

115VAC (Catalog number <i>FDH1...</i> / <i>FPH1...</i>)	Unit	2.5A	5A	7.5A
Switching threshold	VDC	on: 188-195, off: 183-188		
Nominal power (10% power cycle)	kW	0.25		
Peak power (10% power cycle)	kW	2.7		
Maximum regeneration switching current	A_{RMS}	10		
Maximum load inductance	μH	100		

***Note:** 2.5A models (*FDH1A02...* and *FPH1A02...*) contain an internal 175Ω, 20W resistor.
5A models (*FDH1A05...* and *FPH1A05...*) contain an internal 90Ω, 40W resistor.

230VAC (Catalog number <i>FDH2...</i> / <i>FPH2...</i>)	Unit	2.5A	5A	7.5A
Switching threshold	VDC	on: 373-383, off: 362-372		
Nominal power (10% power cycle)	kW	0.25		
Peak power (10% power cycle)	kW	2.7		
Maximum regeneration switching current	A_{RMS}	10		
Maximum load inductance	μH	100		

***Note:** 2.5A models (*FDH2A02...* and *FPH2A02...*) contain an internal 175Ω, 20W resistor.
5A models (*FDH2A05...* and *FPH2A05...*) contain an internal 90Ω, 40W resistor.

230VAC three-phase models (Catalog number <i>FDH2A15...</i> / <i>FPH2A15...</i>)	Unit	15A
Switching threshold	VDC	on: 376, off: 365
Nominal power (10% power cycle)	kW	1.0
Peak power (10% power cycle)	kW	15
Maximum regeneration switching current	A_{RMS}	40
Maximum load inductance	μH	100

230-460VAC three-phase models (Catalog number FDH4... / FPH4...)	Unit	2.5A	5A	7.5A	15A	20A	27.5A
Switching threshold $V_{in}=400VAC$ $V_{in}=460VAC$	VDC	on: 794, off: 787			on: 794, off: 764		
Nominal power (10% power cycle)	kW	0.94			2.9		
Peak power (10% power cycle)	kW	9.4			29		
Maximum regeneration switching current	A_{RMS}	15			40	80	
Maximum load inductance	μH	100					

*Note: 2.5A models (FDH4A02... and FPH4A02...) contain an internal 200Ω, 300W resistor.
5A models (FDH4A05... and FPH4A05...) contain an internal 200Ω, 300W resistor.

7.1.6 Analog input (X3)

All models	Unit	All models
Type		Differential
Common mode voltage range	VDC	±10
Common mode rejection	dB	40
Input impedance	kΩ	>5
Input ADC resolution	bits	14 (includes sign bit)
Equivalent resolution	mV	±1.2
Sampling interval Software (Mint programs) High speed command reference signal	μs	500 125

7.1.7 Digital inputs (X3)

<i>All models</i>	Unit	All models
Type		Opto-isolated DC inputs
Input voltage (Active high) Nominal Minimum	VDC	24 12
Input voltage (Active low) Nominal Maximum	VDC	0 2
Input current (approximate, per input)	mA	5
Sampling interval	ms	2
Maximum pulse input frequency (DIN4, pulse and direction mode)	MHz	1
Minimum pulse width (DIN4/DIN5, pulse and direction mode)	ns	250

7.1.8 Digital outputs (X3)

<i>All models</i>	Unit	All models
Output current (maximum, each output)	mA	50
Update interval Software (Mint programs) DRI VEOKOUTPUT, DRI VEENABLEOUTPUT, and GLOBALERROROUTPUT functions PLC Task functions		Immediate 2ms Programmable

7.1.9 Relay output (X3)

<i>All models</i>	Unit	All models
Contacts		Normally closed
Contact rating (resistive)		1A @ 30VDC or 0.5A @ 125VAC
Maximum carrying current	A	2
Maximum switching power		62.5AV, 30W
Maximum switching voltage		250VAC, 220VDC
Maximum switching current	A	2
Capacitance (between open contacts, at 1kHz)	pF	0.5
Update interval		Immediate

7.1.10 Serial RS232 interface (X6)

<i>All models</i>	Unit	All models
Signal		RS232, non-isolated CTS/RTS
Bit rate	Baud	9600, 19200, 38400, 57600

7.1.11 Serial RS485 interface (X6)

<i>All models</i>	Unit	All models
Signal		4-wire RS485, non-isolated
Bit rate	Baud	9600, 19200

7.1.12 Encoder output (simulated) (X7)

<i>All models</i>	Unit	All models
Signal		RS422
Resolution with resolver input on X8 with encoder input on X8 with absolute encoder input on X8	ppr	Simulated 512 / 1024 / 2048* / 4096* (*Only available if resolver input is set to simulate a 4096ppr source. Output is a copy of the input on X8 Output ppr equals the number of Sin/Cos cycles per revolution of the input. See section 4.4.1.

7.1.13 Resolver feedback option (X8)

<i>Catalog numbers:</i> FDHxxxxxx-Rxxxx FPHxxxxxx-Rxxxx	Unit	All models
Resolution set automatically by software	bits	14
Resolver winding ratio		0.5
FlexDrive^{II} resolver input accuracy	counts	±3
Typical accuracy using Baldor BSM series resolver motor (with input set to simulate 4096 ppr)	counts	±11
Maximum recommended cable length		30.5m (100ft)

7.1.14 Encoder feedback option (X8)

<i>Catalog numbers:</i> FDHxxxxxx-Exxxx FPHxxxxxx-Exxxx	Unit	All models
Encoder input		A/B Differential, Z index
Maximum input frequency (quadrature)	MHz	8
Hall inputs		Single ended, 5V logic
Output power supply to encoder		5V, 200mA max.
Maximum recommended cable length		30.5m (100ft)

7.1.15 EnDat (absolute encoder) feedback option (X8)

<i>Catalog numbers MDHxxxxxx-Dxxxx</i>	Unit	All models
Absolute encoder input		EnDat Sin/Cos differential inputs and data input
Operating modes (Baldor motors)		Single or multi-turn. 512 or 2048 Sin/Cos cycles per turn, with absolute positioning resolution of 2048 or 8192 steps. (Many other encoder specifications are supported - contact Baldor.)
Output power supply to encoder		5V, 200mA max.
Maximum recommended cable length		30.5m (100ft)

7.1.16 Master (auxiliary) encoder input (X9)

<i>All models</i>	Unit	All models
Signal		RS422
Operating mode		A/B quadrature
Maximum input frequency (quadrature)	MHz	2.5
Sampling interval	ms	Software selectable: 1, 2
Output power supply to encoder		5V, 100mA max.

7.1.17 Pulse and direction input (X9)

<i>All models</i>	Unit	All models
Pulse and direction signals		RS422
Input current (5V input)	mA	1.2mA
Maximum input frequency	MHz	1.25
Sampling interval	ms	Software selectable: 1, 2

7.1.18 Environmental

<i>All models</i>	Unit	All models	
Operating temperature range Minimum Maximum Derate		°C	°F
		+0 +40	+32 +104
		2.5% / °C between 40°C and 50°C (max)	2.5% / 1.8°F between 104°F and 122°F (max)
Storage temperature range		-25 to +70	-13 to +158
Humidity	%	10-90 non-condensing according to DIN40 040 / IEC144 Above 31°C (87°F) derate linearly to 50% relative humidity at 40°C (104°F)	
Maximum installation altitude (above m.s.l.)	m	1000 Derate 1.1% / 100m over 1000m	
	ft	3300 Derate 1.1% / 330ft over 3300ft	
Shock		10G according to DIN IEC 68-2-6/29	
Vibration		1G, 10-150Hz, according to DIN IEC 68-2-6/29	

A.1 Introduction

This section describes accessories and options that you may need to use with your FlexDrive^{II}. Shielded (screened) cables provide EMI / RFI shielding and are required for compliance with CE regulations. All connectors and other components must be compatible with the shielded cable.

A.1.1 Factory fitted options

The FlexDrive^{II} can be supplied with a number of factory fitted options. Each option is described in a separate manual that will be supplied with your product as necessary:

- **MN1908 - CAN & Auxiliary I/O Option for Flex+Drive^{II} and MintDrive^{II}.**
Option B provides CANopen and additional input / output capabilities. If this option is fitted, the Flex+Drive^{II} front panel will include connectors X10, X11 and X12.
- **MN1909 - CAN Option for FlexDrive^{II}, Flex+Drive^{II} and MintDrive^{II}.**
Option C provides CANopen capabilities. If this option is fitted, the FlexDrive^{II} front panel will include connectors X10 and X11.
- **MN1910 - DeviceNet Option for FlexDrive^{II}, Flex+Drive^{II} and MintDrive^{II}.**
Option D provides DeviceNet capabilities. If this option is fitted, the FlexDrive^{II} front panel will include connector X15.
- **MN1911 - PROFIBUS DP Option for FlexDrive^{II}, Flex+Drive^{II} and MintDrive^{II}.**
Option P provides Profibus capabilities. If this option is fitted, the FlexDrive^{II} front panel will include connector X14.

A.1.2 Motor power cables

Cable rated current	Cable assembly description	Baldor catalog number	Length	
			ft	m
10 Amps	Power Cable Assembly CE Style Threaded Connector	CBL015SP-MHCE	5	1.5
		CBL030SP-MHCE	10	3.0
		CBL061SP-MHCE	20	6.1
		CBL091SP-MHCE	30	9.1
		CBL152SP-MHCE	50	15.2
		CBL229SP-MHCE	75	22.9
		CBL305SP-MHCE	100	30.5
20 Amps	Power Cable Assembly Threaded connector (Standard-Metric Style)	CBL015SP-FHM	5	1.5
		CBL030SP-FHM	10	3.0
		CBL061SP-FHM	20	6.1
		CBL076SP-FHM	25	7.6
		CBL091SP-FHM	30	9.1
		CBL152SP-FHM	50	15.2
		CBL229SP-FHM	75	22.9
	CBL305SP-FHM	100	30.5	
	Power Cable Assembly CE Style Threaded Connector	CBL030SP-FHCE	10	3.0
		CBL061SP-FHCE	20	6.1
		CBL091SP-FHCE	30	9.1
		CBL152SP-FHCE	50	15.2
	Power Cable No Connectors	CBL030SP-F	10	3.0
CBL046SP-F		15	4.6	
CBL061SP-F		20	6.1	
CBL076SP-F		25	7.6	
CBL091SP-F		30	9.1	
CBL152SP-F		50	15.2	
30 Amps	Power Cable No Connectors	CBL030SP-E	10	3.0
		CBL046SP-E	15	4.6
		CBL061SP-E	20	6.1
		CBL091SP-E	30	9.1
		CBL152SP-E	50	15.2

A.1.3 Motor power cable part numbers

For easier installation, it is recommended that a color-coded Baldor motor power cable is used. A description of a Baldor motor power cable catalog number is shown here, using the example number **CBL030SP-MHCE**:

	Meaning	Alternatives
CBL	The item is a cable	-
030	Indicates the length, in this example 3.0 meters	Various lengths are available
SP	The cable is a S ervo motor P ower cable	-
M	Current rating of 10A	F =20A; E =30A
H	8-pin connector	-
CE	Metric threaded CE connector	M =Metric threaded connector

Motor power cables are also available without connectors, in which case the final letters (**HCE** in the example above) are not used.

A.1.4 Feedback cables

This table lists part numbers of Baldor resolver feedback cables for use with the FlexDrive^{II}:

Feedback type	Cable assembly description	Baldor catalog number	Length	
			ft	m
Resolver	Feedback Cable Assembly Threaded connector (Standard-Metric Style)	CBL015SF-ALM	5	1.5
		CBL030SF-ALM	10	3.0
		CBL061SF-ALM	20	6.1
		CBL091SF-ALM	30	9.1
		CBL152SF-ALM	50	15.2
		CBL229SF-ALM	75	22.9
		CBL305SF-ALM	100	30.5
	Feedback Cable Assembly CE Style Threaded Connector	CBL015SF-ALCE	5	1.5
		CBL030SF-ALCE	10	3.0
CBL061SF-ALCE		20	6.1	
CBL091SF-ALCE		30	9.1	
CBL152SF-ALCE		50	15.2	
CBL229SF-ALCE		75	22.9	
	CBL305SF-ALCE	100	30.5	
Feedback Cable No Connector	CBL030SF-A	10	3.0	
	CBL061SF-A	20	6.1	
	CBL091SF-A	30	9.1	
	CBL152SF-A	50	15.2	
	CBL213SF-A	70	21.3	
	CBL305SF-A	100	30.5	
Encoder/Hall	Feedback Cable Assembly Threaded connector (Standard-Metric Style)	CBL015SF-KPM	5	1.5
		CBL030SF-KPM	10	3.0
		CBL061SF-KPM	20	6.1
		CBL091SF-KPM	30	9.1
		CBL152SF-KPM	50	15.2
		CBL229SF-KPM	75	22.9
		CBL305SF-KPM	100	30.5
	Feedback Cable Assembly CE Style Threaded Connector	CBL015SF-KPCE	5	1.5
		CBL030SF-KPCE	10	3.0
CBL061SF-KPCE		20	6.1	
CBL091SF-KPCE		30	9.1	
CBL152SF-KPCE		50	15.2	
CBL229SF-KPCE		75	22.9	
	CBL305SF-KPCE	100	30.5	
Feedback Cable No Connector	CBL030SF-K	10	3.0	
	CBL061SF-K	20	6.1	
	CBL091SF-K	30	9.1	
	CBL152SF-K	50	15.2	
	CBL213SF-K	70	21.3	
	CBL305SF-K	100	30.5	

A.1.5 Feedback cable part numbers

A description of a Baldor feedback cable catalog number is shown here, using the example number **CBL030SF-ALCE**:

	Meaning	Alternatives
CBL	The item is a cable	-
030	Indicates the length, in this example 3.0 meters	Various lengths are available
SF	The cable is a S ervo motor F eedback cable	-
A	Resolver feedback cable	K =Encoder / Hall feedback cable or EnDat cable
L	12-pin connector (for resolvers and EnDat)	P =16-pin connector (for encoders)
CE	Metric threaded CE connector*	M =Metric threaded connector

***Note:** Feedback cables terminated with a CE connector (catalog numbers CBLxxxx-xx**CE**) have shields tied to the connector housing.

If you are not using a Baldor cable with your chosen feedback device, be sure to obtain a cable that is a shielded twisted pair 0.34mm² (22 AWG) wire minimum, with an overall shield. Ideally, the cable should not exceed 30.5m (100ft) in length. Maximum wire-to-wire or wire-to-shield capacitance is 50pF per 300mm (1ft) length, to a maximum of 5000pF for 30.5m (100ft).

A.1.6 EMC filters

AC filters remove high frequency noise from the AC power supply, protecting the FlexDrive^{II}. These filters also prevent high frequency signals from being transmitted back onto the power lines and help meet CE requirements. To select the correct filter, see section 3.4.5.

A.1.6.1 Catalog numbers

Baldor catalog number	Rated volts	Rated amps @ 40°C	Leakage current (mA)	Weight kg (lbs)
FI0014A00	250	3	0.4	0.27 (0.6)
FI0015A00	250	6	0.4	0.45 (0.99)
FI0015A01	250	10	0.4	0.73 (1.61)
FI0015A02	250	12	0.4	0.73 (1.61)
FI0018A00	480	7.7	33.04	0.5 (1.1)
FI0018A01	480	32.9	33.04	1.2 (2.65)
FI0019A00	250	3	0.4	0.8 (1.76)

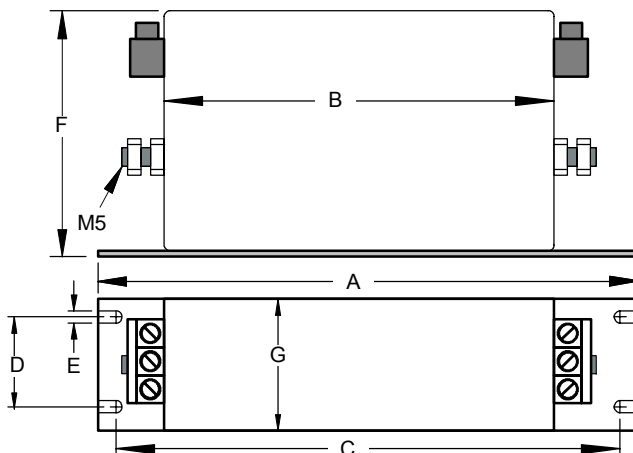

Dimension	Dimensions mm (inches)	
	FI0018A00 / FI0019A00	FI0018A01
A	190 (7.48)	270 (10.63)
B	160 (6.30)	240 (9.45)
C	180 (7.09)	255 (10.04)
D	20 (0.79)	30 (1.18)
E	4.5 (0.18)	5.4 (0.21)
F	71 (2.80)	85 (3.35)
G	40 (1.57)	50 (1.97)

Figure 40 - Filter dimensions, types FI0018A00, FI0018A01 and FI0019A00

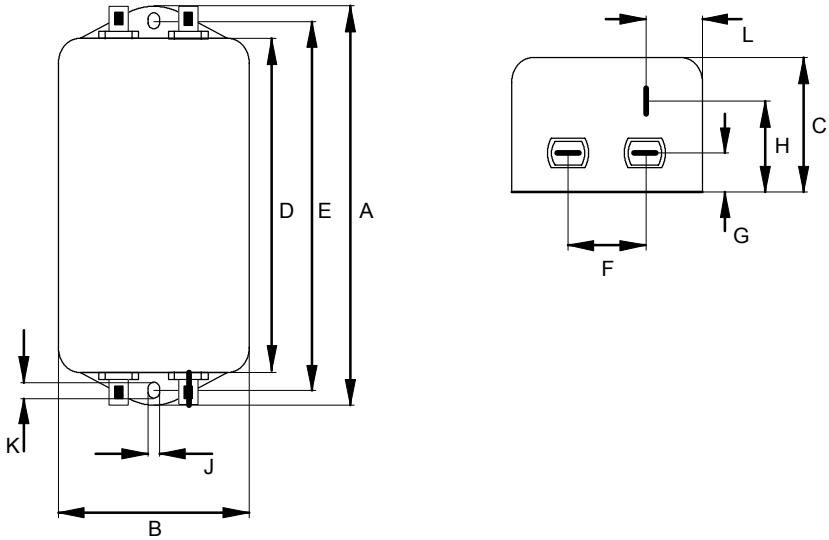

Dimension	Dimensions <i>mm (inches)</i>		
	FI0014A00	FI0015A00	FI0015A01 FI0015A02
A	85 (3.35)	113.5 (4.47)	156 (6.14)
B	54 (2.13)	57.5 (2.26)	
C	40 (1.57)	46.6 (1.83)	
D	65 (2.56)	94 (3.70)	130.5 (5.14)
E	75 (2.95)	103 (4.06)	143 (5.63)
F	27 (1.06)	25 (0.98)	
G	12 (0.47)	12.4 (0.49)	
H	29.5 (1.16)	32.4 (1.28)	
J	5.3 (0.21)	4.4 (0.17)	5.3 (0.21)
K	6.3 (0.25)	6 (0.24)	
L	13.5 (0.53)	15.5 (0.61)	

Figure 41 - Filter dimensions, types FI0014A00, FI0015A00, FI0015A01, FI0015A02

A.1.7 Regeneration resistors

Some FlexDrive^{II} models (2.5A and 5A) are fitted with an internal regeneration resistor (see sections 2.2.1 and 7.1.5). Additional (external) regeneration resistors can be fitted to these models using the R1 and R2 pins of connector X1/X1A. Resistors connected in this way will be in parallel with the internal resistor.

If an internal resistor is not present, a regeneration resistor should be installed to dissipate energy during braking to prevent an over-voltage error occurring.

FlexDrive ^{II} current rating	115VAC 1Φ models		230VAC 1Φ models		230VAC 3Φ models		230-460VAC 3Φ models	
	Baldor catalog no.	Power rating (W)	Baldor catalog no.	Power rating (W)	Baldor catalog no.	Power rating (W)	Baldor catalog no.	Power rating (W)
2.5A	(Internal)		(Internal)				(Internal)	
5A								
7.5A	RG22	100	RG39	100			RG68	320
15A					RG10	320	RG27A	320*
20A							RG27A	320*
27.5A							RG11	640

***Note:** Where the required dissipation could exceed 320W resistor RG23, rated at 640W, can be used instead.

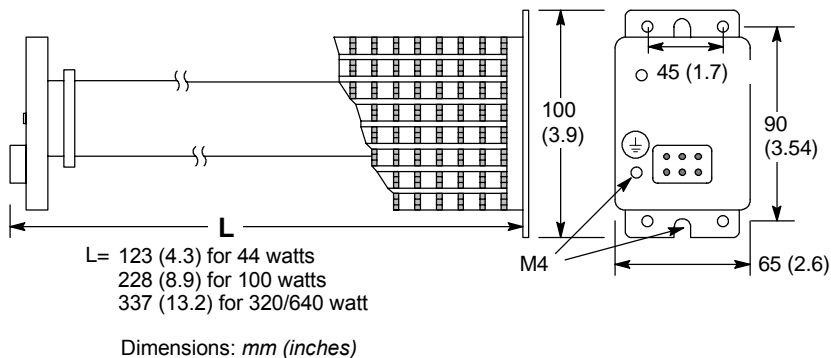

Figure 42 - Regeneration resistor dimensions, all types



WARNING: A regeneration resistor may generate enough heat to ignite combustible materials. To avoid fire hazard, keep all combustible materials and flammable vapors away from the brake resistors. Ensure that the resistor has clearance of at least 50mm (2 in) above and below and 26mm (1 in) left and right.

B.1 Introduction

The FlexDrive^{II} can be configured for three basic control modes:

- Current (Torque) control
- Velocity (Speed) control
- Position Control (Pulse and Direction following/gearing)

The Flex+Drive^{II} can be configured for three basic control modes:

- Current (Torque) control
- Velocity (Speed) control
- Position Control

The mode you require is selected in WorkBench v5 using the Commissioning Wizard. You can subsequently change between these control modes using the Tools, Control Mode menu item or by using the CONTROLMODE keyword in the Command window (see the Mint help file). Using the Parameter tool, you can define a mode for the drive to automatically select at start-up. The four control modes are described in the following sections.

B.1.1 Current (Torque) control

Setting the control mode to Current Control configures the FlexDrive^{II} or Flex+Drive^{II} as a torque amplifier, as shown in Figure 43. Here, a torque reference is obtained from a specified source.

- Mint / host command (profiled)
- High speed analog input (not profiled)
- Analog input (profiled)
- Fieldbus (profiled).

The source provides a signal that can either be fed directly into the Torque controller (only when using the high speed analog input source), or through a profiler. The high speed reference source is ideal for connecting to a motion controller (e.g. NextMove PCI) that will have already profiled the signal and will provide optimum loop closure.

The profiler generates a torque demand signal that smoothly changes between successive torque targets (reference values). This is achieved by specifying a rise time and fall time (see the WorkBench v5 Parameters tool). The torque demand signal is fed into the torque controller which determines the appropriate amount of current to apply to the windings of the motor. This demand current is compared with the actual winding current measured from sensors, and a suitable pulse width modulation (PWM) signal is generated. This PWM signal is fed to the power electronics in the drive.

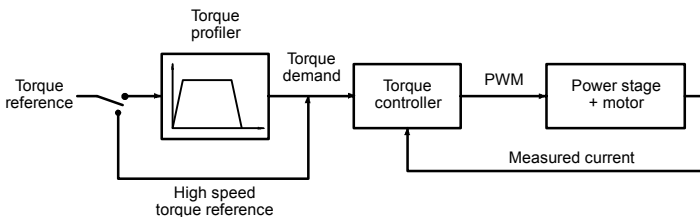

Figure 43 - Control structure in Current (Torque) control mode

B.1.2 Velocity (Speed) control

Setting the control mode to Velocity Control configures the FlexDrive^{II} or Flex+Drive^{II} as a speed amplifier, as shown in Figure 44. Here, a speed reference is obtained from a specified source.

- Mint / host command (profiled)
- High speed analog input (not profiled)
- Analog input (profiled)
- Fieldbus (profiled).

The source provides a signal that can either be fed directly into the Speed controller (only when using the high speed analog input source), or through a profiler. The high speed reference source is ideal for connecting to a motion controller (e.g. NextMove PCI) that will have already profiled the signal and will provide optimum loop closure.

The profiler generates a speed demand signal that smoothly changes between successive speed targets (reference values). This is achieved by specifying acceleration and deceleration times (see the WorkBench v5 Parameters tool). The speed demand signal is fed into the speed controller and used, together with the speed measured from the feedback device, to generate a torque demand signal. If the speed controller is tuned correctly, the measured speed will accurately track the speed demand.

Finally, the torque demand signal is fed into a torque controller, which determines the appropriate amount of current to apply to the windings of the motor. This demand current is compared with the actual winding current measured from sensors, and a suitable pulse width modulation (PWM) signal is generated. This PWM signal is fed to the power electronics in the drive.

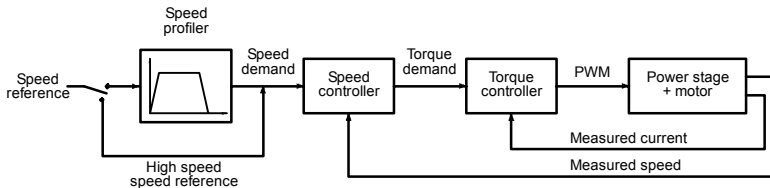

Figure 44 - Control structure in Velocity control mode

B.1.3 Position control (Pulse and Direction)

Setting the control mode to Position Control (Pulse and Direction) configures the FlexDrive^{II} as a positioning system, as shown in Figure 45, capable of following a position command signal.

The profiler interprets the pulse and direction signals and uses them to generate corresponding position, speed and acceleration demand signals.

The position and speed demand signals are fed into a position controller and used, together with the position measured from the feedback device, to generate a suitable speed demand signal. If the position controller is tuned correctly, the measured position will accurately track the position demand.

The speed demand signal from the position controller is fed into the speed controller and used, together with the speed measured from the feedback device, to generate a torque demand signal. If the speed controller is tuned correctly, the measured speed will accurately track the speed demand. To improve the tracking performance of the speed controller, the profiler acceleration demand is fed in at this point.

Finally, the torque demand signal is fed into a torque controller, which determines the appropriate amount of current to apply to the windings of the motor. This demand current is compared with the actual winding current measured from sensors, and a suitable pulse width modulation (PWM) signal is generated. This PWM signal is fed to the power electronics in the drive.

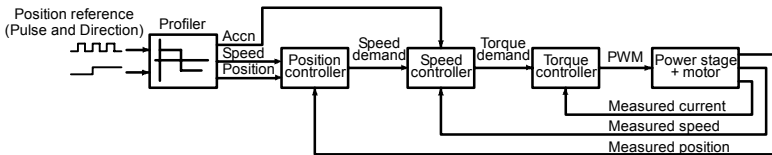

Figure 45 - Control structure in Position control (Pulse and Direction)

B.1.4 Position control

Flex+Drive^{II} only:

Setting the control mode to Position Control configures the Flex+Drive^{II} as a full positioning system, as shown in Figure 46. Here, the Flex+Drive^{II} can be used to command many different position profiles:

- Preset moves
- Absolute or relative moves
- Incremental absolute or relative moves
- Jog control
- Following / Gearing
- Homing

The profiler generates a position demand signal that smoothly changes between successive targets. The profile also generates corresponding speed and acceleration demand signals.

The position and speed demand signals are fed into a position controller and used, together with the position measured from the feedback device, to generate a suitable speed demand signal. If the position controller is tuned correctly, the measured position will accurately track the position demand.

The speed demand signal from the position controller is fed into the speed controller and used, together with the speed measured from the feedback device, to generate a torque demand signal. If the speed controller is tuned correctly, the measured speed will accurately track the speed demand. To improve the tracking performance of the speed controller, the profiler acceleration demand is fed in at this point.

Finally, the torque demand signal is fed into a torque controller, which determines the appropriate amount of current to apply to the windings of the motor. This demand current is compared with the actual winding current measured from sensors, and a suitable pulse width modulation (PWM) signal is generated. This PWM signal is fed to the power electronics in the drive.

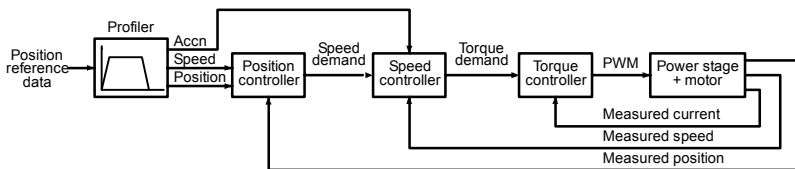

Figure 46 - Control structure in Position control mode

B.2 Control system operation

The following sections describe the operation of the position, speed and torque controllers.

B.2.1 Position controller

The position controller, shown below, is a typical proportional + integral + derivative (PID) controller, with gains set by the Mint keywords `KPROP`, `KINT` and `KDERIV`. The position demand from the profiler is compared with the measured position and the error is fed into the PID control calculation. The resulting value forms the basic speed or torque demand, depending on the `CONFIG` setting. The effect of the integral term can be changed using the `KINTLIMIT` and `KINTMODE` keywords. `KINTLIMIT` sets the maximum value of the effect of integral action, as a percentage of the full scale demand. `KINTMODE` can be used to specify the circumstances under which the integral term is applied.

As an alternative to the derivative term, a velocity feedback term is available by setting keyword `KVEL`.

To improve the tracking performance of the position controller, the profiler speed is fed forward, by gain `KVELFF`, to give a contribution to the final speed or torque demand. The profiler acceleration is fed forward by gain `KACCEL` to give a contribution to the final speed demand. The position control calculation is performed every 500 μ s.

The gain values `KPROP`, `KINT`, `KDERIV`, `KVEL`, `KVELFF` and `KACCEL` must be tuned for each application. This can either be performed automatically within the Commissioning Wizard, or manually using the Fine-tuning tool in WorkBench v5.

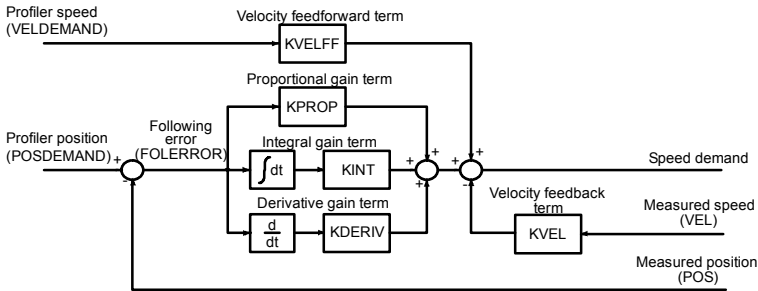

Figure 47 - Position control system

B.2.2 Speed controller

The speed controller, shown in Figure 48, is also a PID controller. Gains are set using the Mint keywords `KVPROP`, `KVINT` and `KVDERIV`. The speed is compared with the measured speed and the error is fed into the PID control calculation. The result forms the torque demand for the torque controller. To improve the performance of the derivative term, an optional filter is included. The time constant of this filter can be set using keyword `KVDERIVTCONST`. By default the filter is turned off, with `KVDERIVTCONST` set to zero.

When the FlexDrive^{II} is set to positioning mode (`CONFIG` is `_cfSERVO`), the profiler acceleration is fed forward by gain `KACCEL` to give a contribution to the final torque demand. The speed control calculation is performed every $250\mu\text{s}$. As with the position controller, the gain values `KVPROP`, `KVINT`, `KVDERIV` and `KACCEL` must be tuned for each application. This can either be performed automatically within the Commissioning Wizard, or manually using the Fine-tuning tool of WorkBench v5.

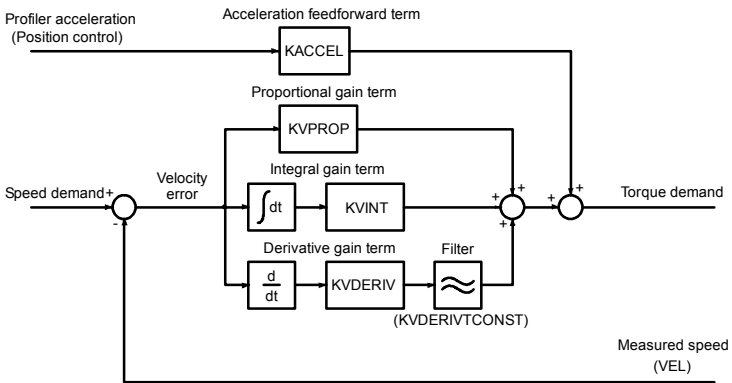

Figure 48 - Speed control system

B.2.3 Torque controller and feedback

The torque controller, shown in Figure 49, is a PI controller. Gains are set using the Mint keywords `KI PROP` and `KI INT`. The torque demand is scaled into a current demand. This is compared with the measured current, obtained from the current sensors, and the error is fed into the PI control calculation. The resulting value forms the PWM signal that is fed through the power stage into the motor windings. The gain values `KI PROP` and `KI INT` must be tuned for a specific motor. This is performed automatically by the Commissioning Wizard.

Although the PI control alone can achieve adequate current tracking if tuned correctly, performance is increased using a feedforward voltage model. This model compensates for the voltage drop due to stator resistance (set using the `MOTORRS` keyword) and stator leakage inductance (set using the `MOTORLS` keyword). It also compensates for the back EMF of the motor, with the voltage constant of the motor being set using the `MOTORFLUX` keyword. Values for `MOTORRS`, `MOTORLS` and `MOTORFLUX` are set automatically by the Commissioning Wizard. The torque control calculation is performed every 125µs.

The feedback device (e.g. an encoder or resolver) is used to determine motor position and speed. Motor speed can be filtered to reduce measurement noise if necessary. The time constant of this filter is specified using the keyword `KVTIME`. By default the filter is turned off (`KVTIME = 0`). Note that introducing a filter on measured speed tends to reduce the stability of the speed controller. This can make the tuning of the speed controller gains difficult if large values of `KVTIME` are used.

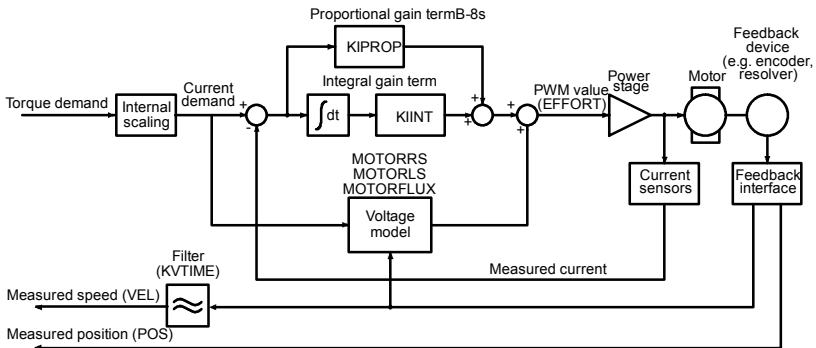

Figure 49 - Torque control system

C.1 Outline

This section provides general information regarding recommended methods of installation for CE compliance. It is not intended as an exhaustive guide to good practice and wiring techniques. It is assumed that the installer of the FlexDrive^{II} is sufficiently qualified to perform the task, and is aware of local regulations and requirements. Baldor products that meet the EMC directive requirements are indicated with a “CE” mark. A duly signed CE declaration of conformity is available from Baldor.



C.1.1 EMC Conformity and CE marking

The information contained herein is for your guidance only and does not guarantee that the installation will meet the requirements of the council directive 89/336/EEC.

The purpose of the EEC directives is to state a minimum technical requirement common to all the member states within the European Union. In turn, these minimum technical requirements are intended to enhance the levels of safety both directly and indirectly.

Council directive 89/336/EEC relating to Electro Magnetic Compliance (EMC) indicates that it is the responsibility of the system integrator to ensure that the entire system complies with all relative directives at the time of installing into service.

Motors and controls are used as components of a system, per the EMC directive. Hence all components, installation of the components, interconnection between components, and shielding and grounding of the system as a whole determines EMC compliance.

The CE mark informs the purchaser that the equipment has been tested and complies with the appropriate standards. It rests upon the manufacturer or his authorized representative to ensure the item in question complies fully with all the relative directives in force at the time of installing into service, in the same way as the system integrator previously mentioned. Remember that it is the instructions of installation and the product that should comply with the directive.

C.1.2 Use of CE compliant components

The following points should be considered:

- **Using CE approved components will not guarantee a CE compliant system!**
- The components used in the drive, installation methods used, materials selected for interconnection of components are important.
- The installation methods, interconnection materials, shielding, filtering and earthing/grounding of the system as a whole will determine CE compliance.
- The responsibility of CE mark compliance rests entirely with the party who offers the end system for sale (such as an OEM or system integrator).

C.1.3 EMC wiring technique

Cabinet

Using a typical electroplated zinc coated enclosure, connected to earth/ground, means that all parts mounted on the back plane are connected to earth/ground and all outer shield (screen) connections can be connected to earth/ground. Within the cabinet there should be a spatial separation between power wiring (motor and AC power cables) and control wiring.

Shield (screen) connections

All connections between components must use shielded cables. The cable shields must be connected to the enclosure. Use conductive clamps to ensure good earth/ground connection. With this technique, a good earth/ground shield can be achieved.

EMC filters

The filter should be mounted next to the FlexDrive^{II}. The connections between the FlexDrive^{II} and the filter should use shielded (screened) cables. The cable shields should be connected to shield clamps at both ends. An exception to this is the analog command signal.

Earthing/grounding

For safety reasons (VDE0160), all Baldor components must be connected to earth/ground with a separate wire. Earth/ground connections must be made from the central earth/ground (star point) to the regeneration resistor enclosure and from the central earth/ground (star point) to the power supply.

C.1.4 EMC installation suggestions

To ensure electromagnetic compatibility (EMC), the following installation points should be considered to help reduce interference:

- Earthing/grounding of all system elements to a central earth/ground point (star point)
- Shielding of all cables and signal wires
- Filtering of power lines.

A proper enclosure should have the following characteristics:

- All metal conducting parts of the enclosure must be electrically connected to the back plane. These connections should be made with an earthing/grounding strap from each element to a central earthing/grounding point (star point). *
- Keep the power wiring (motor and power cable) and control wiring separated. If these wires must cross, be sure they cross at 90 degrees to minimize noise due to induction.
- The shield connections of the signal and power cables should be connected to the shield rails or clamps. The shield rails or clamps should be conductive clamps fastened to the cabinet. **
- The cable to the regeneration resistor must be shielded. The shield must be connected to earth/ground at both ends.
- The location of the AC filter has to be situated close to the drive so the AC power wires are as short as possible.
- Wires inside the enclosure should be placed as close as possible to conducting metal, cabinet walls and plates. It is advised to terminate unused wires to chassis ground.*
- To reduce earth/ground current, use the largest suitable wire available for earth/ground connections.

* Earthing/grounding in general describes all metal parts which can be connected to a protective conductor, e.g. housing of cabinet, motor housing, etc. to a central earth/ground point (star point). This central earth/ground point (star point) is then connected to the main plant (or building) earth/ground.

** Or run as twisted pair at minimum.

C.1.5 Wiring of shielded (screened) cables

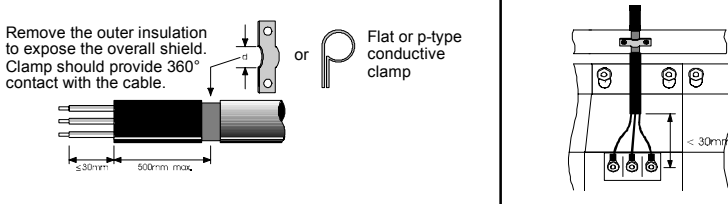

Figure 50 - Earthing/grounding cable shields

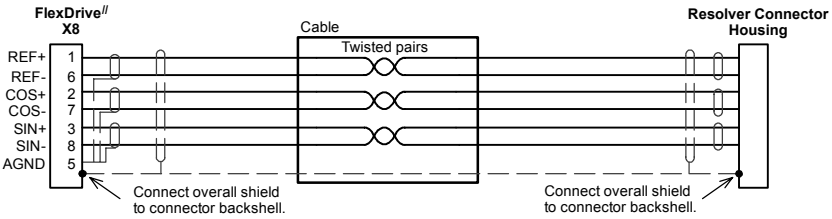

Figure 51 - Resolver cable grounding

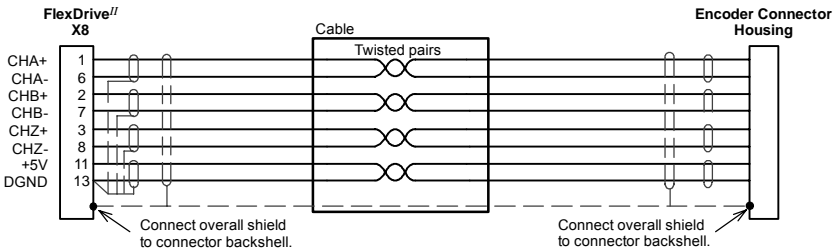

Figure 52 - Encoder signal cable grounding

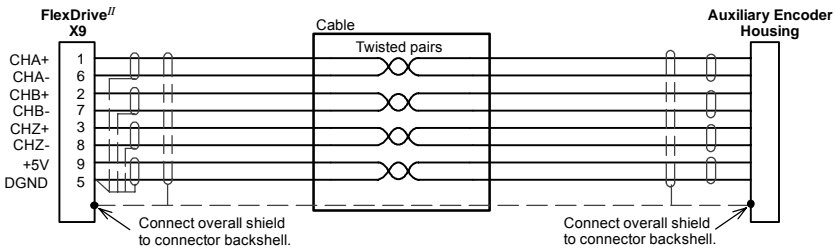

Figure 53 - Auxiliary Encoder cable grounding

A

Abbreviations. *See* Units and Abbreviations

Absolute encoder

- cable, 3-28
- option, 3-27
- specification, 7-9

Accessories, A-1

- EMC filters, A-5
- feedback cables, A-3
- motor power cables, A-2
- regeneration resistors, A-7

Analog I/O, 4-1

- analog input - X3 (command), 4-2

B

Basic Installation, 3-1

C

Catalog number, identifying, 2-2

CE Guidelines, C-1

Commissioning Wizard, 5-7

- completing, 5-7
- using, 5-7

Configuration, 5-8

Connections

- See also* Input / Output
- feedback, 3-21
- motor, 3-15
- motor brake, 3-19
- power, 3-8
 - single phase, 3-9
 - three phase, 3-10
- thermal switch, 3-18

Connector, locations, 3-7

Control system, B-1

- current (torque) control, B-2
- operation
 - position controller, B-6

- speed controller, B-7

- torque controller and feedback, B-8

- position control, B-5

- position control (pulse & direction), B-4

- velocity (speed) control, B-3

D

DB On LED, 6-5

Digital I/O, 4-5

- CREF, 4-7
- digital inputs - X3, 4-6
- digital outputs - X3, 4-9
- pulse & direction, 4-7
- special functions, 4-8

Dimensions, 3-6

DIP switches, 3-31

- 1-4: Node select, 3-31
- 5: Hold, 3-32
- 6: RS485 terminator, 3-32
- 7: Offset tuning, 3-32, 5-3
- 8: Enable, 3-32
- 9 & 10: RS232/RS485 select, 3-33
- factory settings, 3-33
- preventing a program running, 3-34

Drive enable

- command, 3-30
- DIP switch 8, 3-30
- X3 CREF, 3-29

Dynamic brake. *See* Regeneration resistor

E

Encoder

- absolute. *See* Absolute encoder
- cable, 3-25, A-3
- option, 3-24
- specification, 7-9

Environmental

- location, 3-4–3-5
- specification, 7-11

F

Factory fitted options, A-1

Factory settings, 3-33

Features, 2-1

Feedback

absolute encoder, 3-27

cable, A-3–A-4

connections, 3-21

encoder, 3-24

resolver, 3-22

Filters

24V control supply, 3-14

AC power (EMC), 3-12, A-5

catalog numbers, A-5

G

General Information, 1-1

H

Hardware requirements, 3-1

Help file, 5-4

I

Indicators, 6-2

DB On LED, 6-5

Status display, 6-2

Input / Output, 4-1

analog I/O, 4-1

analog input - X3, 4-2, 7-6

connection summary, 4-18

digital I/O, 4-5

digital inputs - X3, 4-6, 7-7

digital outputs - X3, 4-9, 7-7

encoder output - X7, 4-10, 7-8

master encoder input - X9, 4-12, 7-10

option connectors, 4-19

relay - X3, 4-4, 7-8

serial port - X6, 4-14, 7-8

connecting Baldor HMI panels, 4-17

multidrop using RS485/RS422 cable, 4-16

using RS232 cable, 4-15

Installation

See *also* Basic Installation

dimensions, 3-6

mechanical, 3-4

mounting, 3-5

L

LED indicators

DB On, 6-5

Status display, 6-2

M

Motor

circuit contactors, 3-16

connections, 3-15

power cable, 3-16–3-17, A-2

Motor brake, connection, 3-19

Mounting, 3-5

O

Operation, 5-1

connecting to the PC, 5-1

installing software, 5-1

offset tuning, 3-32, 5-3

power on checks, 5-2

preliminary checks, 5-2

starting, 5-2

Options, A-1

P

Power

24V control supply, 3-14

connections, 3-8

disconnect and protection devices, 3-11

input conditioning, 3-11

input cycling, 3-11, 6-1

sources, 3-1

supply filters, 3-12, A-5

Precautions, 1-2

Product Notice, 1-2

Pulse & Direction

following, 4-13

specification, 7-7, 7-10

X3 - DIN4/5, 4-7

X9, 4-12

R

Receiving and Inspection, 2-2

Regeneration

controlling, 3-20

resistor, 3-20

specification, 7-5

Relay

output, 4-4

specification, 7-8

Resolver

cable, 3-23, A-3

option, 3-22

specification, 7-9

RS232

cable, 4-15

specification, 7-8

X6, 4-14

RS485 / RS422

specification, 7-8

systems, 3-2

X6, 4-14–4-17

S

Safety Notice, 1-2

Specifications, 7-1

115V / 230V single-phase models, 7-2

230V three-phase models, 7-3

230V-460V three-phase models, 7-4

24V control supply, 7-4

absolute encoder feedback - X8, 7-9

analog input - X3, 7-6

digital inputs - X3, 7-7

digital outputs - X3, 7-7

encoder feedback - X8, 7-9

encoder output - X7, 7-8

environmental, 7-11

master encoder input - X9, 7-10

pulse & direction inputs - X9, 7-10

regeneration, 7-5

relay output - X3, 7-8

resolver feedback - X8, 7-9

serial RS232 interface - X6, 7-8

serial RS485 interface - X6, 7-8

Status display, 6-2

T

Thermal switch, connection, 3-18

Tools, 3-2

Troubleshooting, 6-1

communication, 6-5

DB On LED, 6-5

power cycling, 6-1

power on, 6-6

problem diagnosis, 6-1

Status display, 6-2

SupportMe, 6-1

tuning, 6-6

U

Units and abbreviations, 2-3

W

Wire sizes, 3-13

WorkBench v5, 5-4

Commissioning Wizard, 5-7

digital I/O tool, 5-11

fine-tuning tool, 5-8

help file, 5-4

other tools and windows, 5-11

parameters tool, 5-10

starting, 5-5

If you have any suggestions for improvements to this manual, please let us know. Write your comments in the space provided below, remove this page from the manual and mail it to:

Manuals
Baldor UK Ltd
Mint Motion Centre
6 Bristol Distribution Park
Hawkey Drive
Bristol
BS32 0BF
United Kingdom.

Alternatively, you can e-mail your comments to:

manuals@baldor.co.uk

Comment:

continued...



Thank you for taking the time to help us.

BALDOR

MOTORS, DRIVES & GENERATORS

Baldor Electric Company
P.O. Box 2400
Ft. Smith, AR 72902-2400
U.S.A.

Visit www.supportme.net for the latest documentation and software releases.

Australia Australian Baldor PTY Ltd Tel: +61 2 9674 5455 Fax: +61 2 9674 2495	Mexico Baldor de Mexico Tel: +52 477 761 2030 Fax: +52 477 761 2010
Europe Baldor ASR GmbH, Germany Tel: +49 (0) 89 905 080 Fax: +49 (0) 89 905 08491	Singapore Baldor Electric PTE Ltd Tel: +65 744 2572 Fax: +65 747 1708
Europe (Southern) Baldor ASR AG, Switzerland Tel: +41 52 647 4700 Fax: +41 52 659 2394	United Kingdom Baldor UK Ltd Tel: +44 1454 850000 Fax: +44 1454 859001
Japan Baldor Japan Corporation Tel: +81 45 412 4506 Fax: +81 45 412 4507	U.S.A. (Headquarters) Baldor Electric Company Tel: +1 479 646 4711 Fax: +1 479 648 5792
For additional office locations visit www.baldor.com	

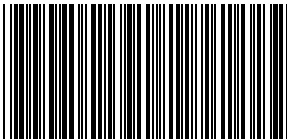

LT0160A02

Printed in UK
© Baldor UK Ltd